

REXSCRUB - OPERATION MANUAL

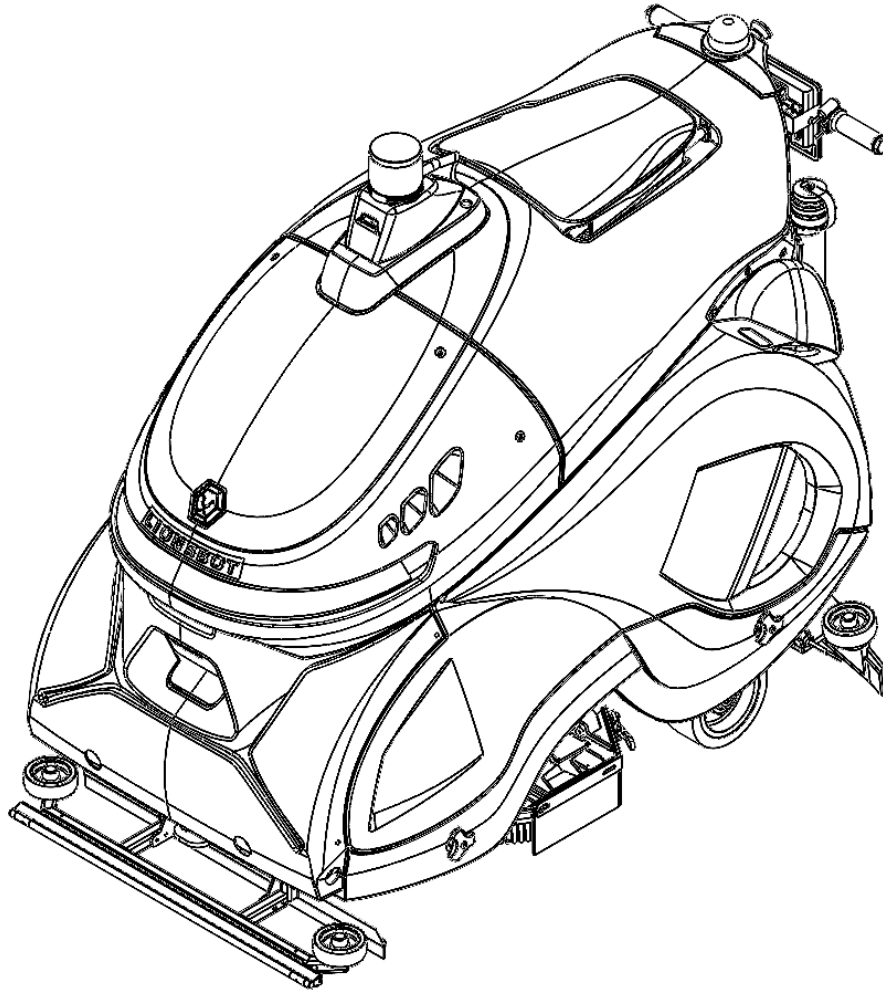

AUTONOMOUS CLEANING ROBOT – FLOOR SCRUBBING

English (EN)

QR
CODE

For the latest Manuals and other language Operator Manuals, Visit:

www.lionsbot.com/contact-us

OPERATION MANUAL

Rev. 02(01-2022)



ORIGINAL INSTRUCTIONS MANUAL



CONTENTS

| | |
|--|-----------|
| CONTENTS | 2 |
| INTRODUCTION TO THE REXSCRUB..... | 5 |
| MAIN REXSCRUB COMPONENTS..... | 6 |
| CONTROLS AND INSTRUMENTATION | 8 |
| INTENDED USAGE ENVIRONMENT | 9 |
| GENERAL SAFETY | 10 |
| DESCRIPTION OF SYMBOLS | 10 |
| PICTORIAL INDICATIONS | 11 |
| CHARGING THE BATTERIES | 12 |
| USING THE REXSCRUB..... | 14 |
| STATUS MONITORING SYSTEM | 17 |
| DEACTIVATION AND STORAGE..... | 17 |
| CLEANING AND MAINTENANCE | 18 |
| TRANSPORT | 19 |
| REMOVING THE SIDE PANELS | 21 |
| ANCHOR AND JACK POINTS ON REX | 22 |
| DISPOSAL..... | 24 |
| EMERGENCY STOP ACTIVATION..... | 24 |
| WARNING ON NOISE LEVEL | 24 |
| NAME PLATE..... | 24 |
| SYMBOLS ON THE REXSCRUB..... | 25 |
| TECHNICAL DATA | 29 |
| HUMAN SAFETY FEATURES OF THE REXSCRUB | 31 |
| DISTANCE SENSORS..... | 32 |
| SAFETY BUMPER..... | 38 |
| OBSTACLE AVOIDANCE | 39 |
| EMERGENCY STOP..... | 40 |
| PERSONALITY OF THE REXSCRUB | 40 |
| LED LIGHTS | 40 |
| RECEIVING AND PREPARING THE REXSCRUB | 40 |

| | |
|---|-----------|
| HANDLING THE PACKAGED ROBOT..... | 41 |
| UNPACKING THE ROBOT | 41 |
| BATTERY INSTALLATION..... | 42 |
| CHARGING THE BATTERY | 45 |
| POWERING ON/OFF THE REXSCRUB..... | 47 |
| BRUSH ASSEMBLY..... | 48 |
| CLEANING THE BRUSHES..... | 50 |
| MOUNTING THE RUBBER GUARDS | 51 |
| CLEANING THE RUBBER GUARDS..... | 52 |
| SQUEEGEE ASSEMBLY | 52 |
| MOUNTING THE SQUEEGEE ASSEMBLY..... | 54 |
| CLEANING THE SQUEEGEE | 55 |
| REXSCRUB TOUCHSCREEN SETUP | 57 |
| INITIAL SETUP..... | 58 |
| LOGIN WITH LOCAL ACCOUNT | 61 |
| LOGIN WITH LIONSBOT ID (OPTIONAL) | 61 |
| USER ACCOUNT MANAGEMENT | 62 |
| TEACH ROBOT | 63 |
| CHANGE MAP | 67 |
| JUST CLEAN | 68 |
| MANUAL CLEAN | 70 |
| SETTINGS..... | 71 |
| REPORTS..... | 73 |
| BEFORE REXSCRUB USE | 74 |
| TRANSPORTING THE REXSCRUB OUT OF STORAGE..... | 74 |
| CHECKING THE WATER LEVEL | 75 |
| FILLING THE CLEAN WATER TANK..... | 75 |
| CHECKING THE BATTERY LEVEL..... | 77 |
| LOCALIZING THE ROBOT | 77 |
| VERIFICATION OF LOCALIZATION..... | 79 |
| OPERATION OF THE REXSCRUB..... | 80 |
| POINT TO POINT MOVEMENT..... | 82 |
| AUTONOMOUS CLEANING..... | 83 |



| | |
|---|------------|
| RECOMMENDED MAINTENANCE | 86 |
| DRAINING THE RECOVERY TANK..... | 88 |
| CLEANING THE RECOVERY TANK..... | 89 |
| DRAINING THE CLEAN WATER TANK..... | 91 |
| CLEANING THE CLEAN WATER TANK | 93 |
| REPLACING THE BRUSHES | 94 |
| REPLACING THE PADS | 94 |
| BRUSHES AND PADS REPLACEMENT | 95 |
| DETACHING THE SQUEEGEE HOSE..... | 96 |
| REPLACING THE SQUEEGEE RUBBER..... | 97 |
| WIPING DOWN THE REXSCRUB..... | 97 |
| STORAGE IN COLD CLIMATES..... | 97 |
| PERIODIC MAINTENANCE | 98 |
| REPLENISHING THE CHEMICAL..... | 99 |
| CHANGING THE WATER FILTER..... | 100 |
| CHARGING THE BATTERY | 101 |
| UPDATING THE MAPS | 101 |
| BATTERY INSTALLATION AND REPLACEMENT..... | 101 |
| DISPOSAL..... | 102 |
| BATTERY DISPOSAL | 102 |
| TROUBLESHOOTING | 103 |
| CONTACT INFORMATION | 104 |
| DISTRIBUTOR INFORMATION | 104 |
| APPENDIX A..... | 104 |
| Hazards Identification | 104 |
| Composition / Information on Ingredients..... | 104 |
| First-Aid Measures | 105 |
| Exposure Controls/Personal Protection..... | 106 |

INTRODUCTION TO THE REXSCRUB



The REXSCRUB is an autonomous floor-scrubbing robot developed by Lionsbot. The REXSCRUB is equipped with two brushes/ scouring pads for floor scrubbing and a squeegee with vacuum suction for wiping the floor dry. The brushes, vacuum and squeegee are activated automatically or manually during cleaning operations.



All work with the REXSCRUB can be carried out through the touchscreen or LionsClean mobile app.

This document introduces the user to the overall structure and components of the REXSCRUB, safety precautions related to its use, and the procedures for work preparation, cleaning, and maintenance with the REXSCRUB. Any questions pertaining to this manual or REXSCRUB operation in general should be directed to the respective distributor or the original manufacturer (see '[DISTRIBUTOR INFORMATION](#)' or '[CONTACT INFORMATION](#)' sections).

This machine will provide excellent service. However, the best results will be obtained at minimum costs if:

- The machine is operated with reasonable care.
- The machine is maintained regularly - per the machine maintenance instructions provided.
- The machine is maintained with manufacturer supplied or equivalent parts.

| | | |
|---|---|--|
|  |  | <p>Read this manual completely and understand the machine before operating or servicing it.</p> |
|---|---|--|

| | |
|---|--|
|   | <p>PROTECT THE ENVIRONMENT</p> <p>Please dispose of packaging materials, used components such as batteries and fluids in an environmentally safe way according to local waste disposal regulations.</p> |
|---|--|

This operator manual contains information to allow for quick start-up of the REXSCRUB, powered by LionsOS. This document may be periodically revised. The REXSCRUB, can be used in manual mode or as a robotic scrubber. Use in robotic (autonomous) mode requires a subscription to Lionsbot International Autonomy Services. It is important to follow all provided instructions and warnings. Failure to adhere to instructions could result in damage to the machine and injury. The REXSCRUB is a commercial floor scrubber powered by LionsOS software. The powered scrubber is capable of functioning in either manual or robotic (autonomous, self-driving) modes. When in robotic mode, the LionsOS software enables autonomous navigation. This product may be covered by one or more patents or pending patent applications. Email LionsBot International for details. Discrete portions of this product were made possible by open-source software. Please email LionsBot International for details.

MAIN REXSCRUB COMPONENTS

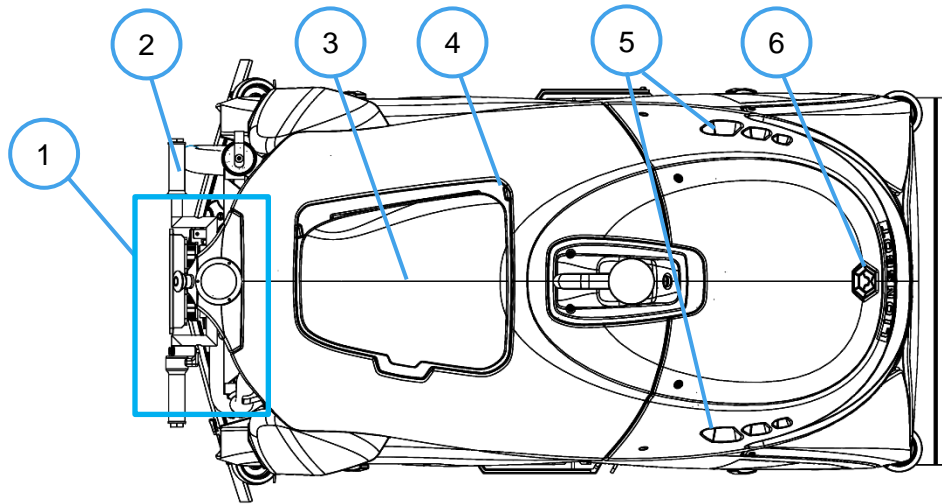

Fig. 1

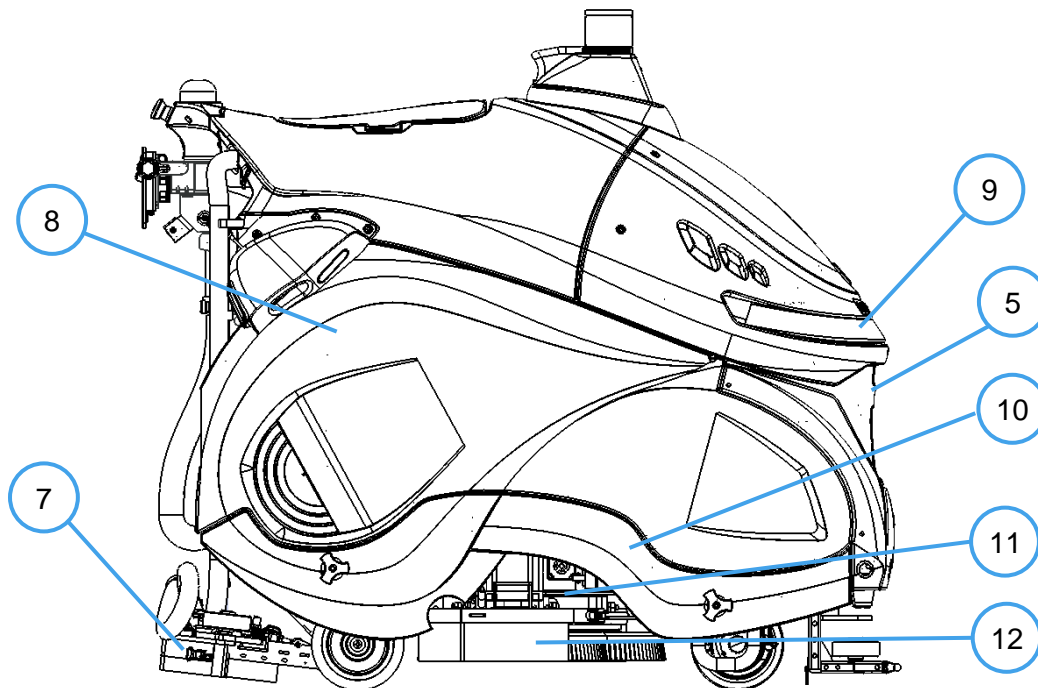

Fig. 2

- | | |
|------------------------|---------------------------|
| 1. CONTROL PANEL | 7. SQUEEGEE ASSEMBLY |
| 2. STEERING MECHANISM | 8. CLEAN WATER TANK |
| 3. RECOVERY TANK COVER | 9. FRONT LED LIGHT |
| 4. RECOVERY TANK | 10. SIDE COVER |
| 5. VENTS | 11. BRUSH ASSEMBLY |
| 6. LIONS BOT LOGO | 12. BRUSH PERIMETER GUARD |

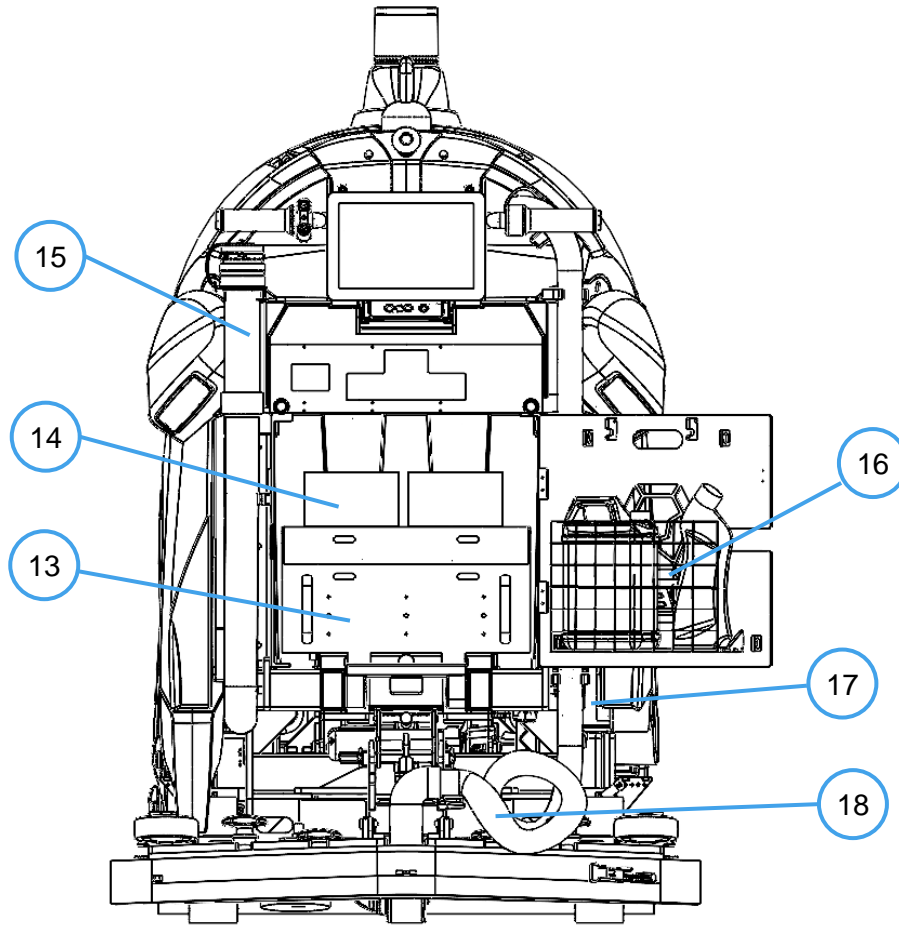

Fig. 3

- 13. BATTERY RACK
- 14. BATTERIES
- 15. RECOVERY HOSE
- 16. CHEMICAL CABINET
- 17. CLEAN WATER INLET
- 18. SQUEEGEE HOSE



CONTROLS AND INSTRUMENTATION

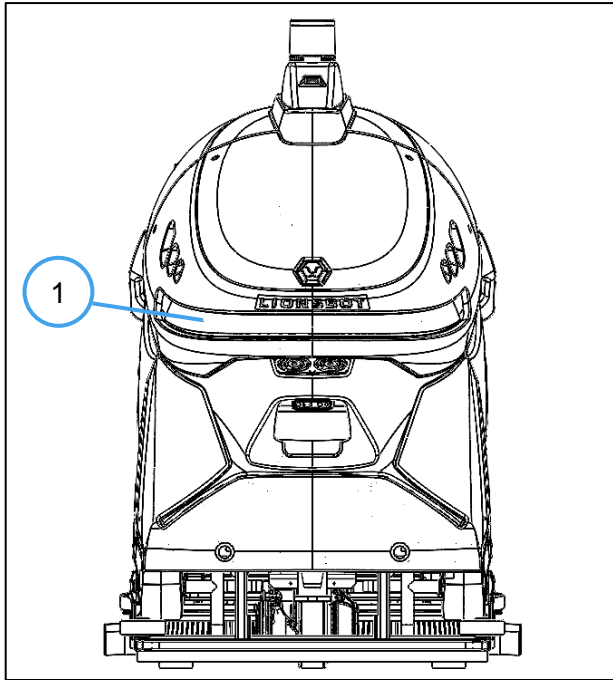

Fig. 1

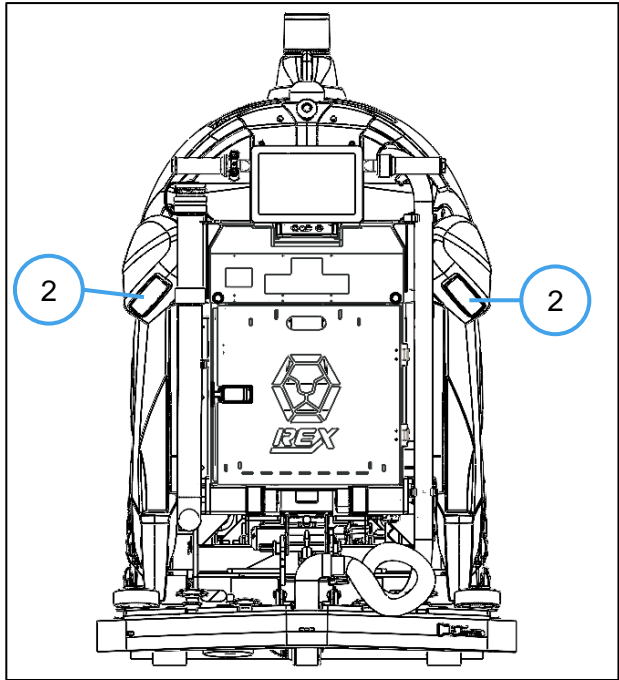

Fig. 2

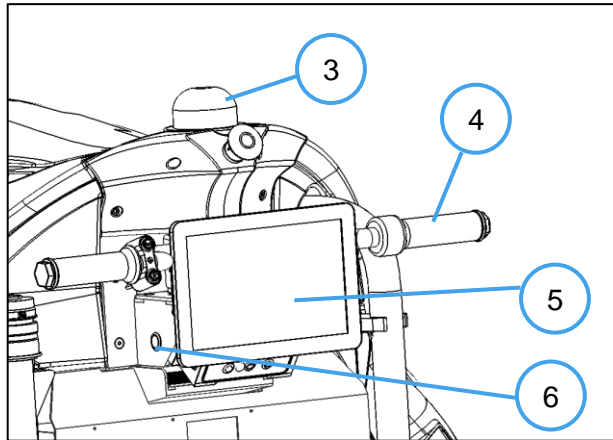

Fig. 3

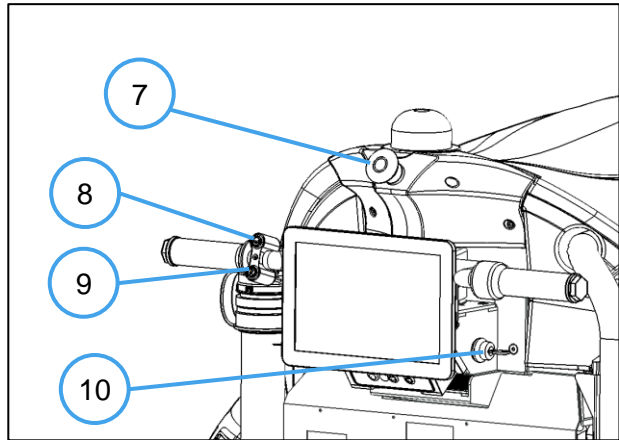

Fig. 4

- 1. FRONT LED
- 2. REAR LEDs
- 3. BEACON LIGHT
- 4. THROTTLE
- 5. TOUCHSCREEN
- 6. REVERSE BUTTON

- 7. EMERGENCY STOP
- 8. HORN BUTTON
- 9. REVERSE BUTTON
- 10. KEY SWITCH

INTENDED USAGE ENVIRONMENT

The REXSCRUB is designed and built for the cleaning (scrubbing and drying) of smooth, compact flooring in an enclosed environment (ex. gymnasiums, convention centers, airports, warehouses etc.) by a qualified operator or trained operator in proven safety conditions. It is only intended to be used in an enclosed indoor environment. This machine is not intended for use on public roadways and narrow areas less than 10 m². Only use this machine as described in operation manual.

Use the machine in approved environments in accordance with the Lionsbot Software End User License Agreement (EULA). Approved environments shall also be limited to cleaning areas with adequate cellular communication signals permitting cellular data communication with the machine to enable periodic safety-related updates.

The operator is responsible for the use of each REXSCRUB in both manual and robotic mode. As the machine begins robotic operation, observe scrubbing performance to ensure that all components are functioning properly. Each operator must be mindful to use the machine in accordance with its intended use and precautions at all times. Operators will not engage in any of the following conduct or activities with respect to the Autonomy Services or LionsOS:

- Transmission of any software or other materials that contain any viruses, worms, trojan horses, defects, spyware, spiders, screen-scrapers, or other items of a destructive or disruptive nature;
- The machine onboard cameras may capture images of people who happen to be in its surrounding. There may be local laws of operation relating to use of technology with cameras. Please comply with all applicable laws, including using signage or obtaining consents as required; Lions cloud does not store any images or video captured by the robot.
- Exploitation of the Autonomy Services, LionsOS, hardware in any unauthorized manner, including by trespassing or burdening server or network capacity or infrastructure;
- Framing, mirroring, or reselling any part of the Autonomy Services or LionsOS without written authorization from Lionsbot International;
- Unauthorized collection of user information; or
- Attempting to deliberately damage the Autonomy Services or LionsOS, or undermine the legitimate operation of the Autonomy Services or LionsOS.



GENERAL SAFETY

This section consists of safety information which must be read and understood by the user before the first usage of the robot. Operator cooperation is paramount for accident prevention; most workplace accidents are caused by a failure to adhere to safety regulations. An attentive and careful user is the most effective guarantee against accidents.

The following symbols are used to indicate any potentially hazardous situations. Please take the necessary precautions to protect people and objects that may be present around the REXSCRUB.









DESCRIPTION OF SYMBOLS

The following symbols categories explain the level of harm or damage that can occur if warnings are not observed and the machine or related equipment is used incorrectly. Understand these symbols and their correlating meanings before reading the remainder of this manual.

| | |
|---|--|
|  | <p>DANGER: Indicates an imminent hazardous situation which, if not avoided, could result in serious injury or death.</p> |
|  | <p>WARNING: Indicates a potentially hazardous situation which, if not avoided, could result in injury or major damage to the equipment.</p> |
|  | <p>CAUTION: Indicates a situation which, if not avoided, could result in major damage to the equipment or injury to the user.</p> |

PICTORIAL INDICATIONS

The following pictorial indication categories explain information to be observed. Read this guide after thoroughly understanding the information.

| | |
|---|--|
|  | <p>NOTE: Indicates safety information, precautions on dos and don'ts to ensure safe product usage and/or user safety.</p> |
|  | <p>COMPULSORY: Action based on instruction must be performed.</p> |
|  | <p>PROHIBITED: Not allowed action. Do not perform any operation not given in this manual. Use of the machine in a manner inconsistent with this manual may lead to personal injury or significant physical damage or property damage.</p> |
|  | <p>NO WATER EXPOSURE: Do not expose to water or moisture.</p> |
|  | <p>UNPLUG: Unplug from power outlet.</p> |
|  | <p>Recycling symbol: Informs the user to carry out the operations in compliance with environmental regulations in force in the place of usage of the appliance</p> |
|  | <p>Bin Symbol: To indicate that separate collection for waste electric and electronic equipment (WEEE) is required.</p> |
|  | <p>Wear Gloves</p> |
|  | <p>Wear Protective Eyewear</p> |

CHARGING THE BATTERIES



DANGER



- Only charge GEL or AGM batteries on the REX. Product warranty shall be void if flooded (wet) lead acid batteries are used. Warranty shall be voided if instructions in this manual are not followed.
- If the battery charge cable is damaged or broken, it should be replaced by the manufacturer or authorized service personnel or a qualified person in order to prevent hazards.
- Keep sparks, flames and incandescent materials at a safe distance from the batteries. Batteries emit hydrogen gas when charging, keep chemical cabinet open when charging.
- Keep the chemical cabinet open during the entire battery recharging cycle, and only perform the procedure in well-ventilated areas at a safe distance from any open flames



- The socket for the battery charger cable must have a prescribed earth connection. Do not modify the polarized plug to fit a non-polarized outlet or extension cord.



- Do not use extension cords or outlets with inadequate current carrying capacity.
- Before charging check that the electric cable that connects the battery charger to the batteries is not damaged, and if it is damaged do not use it and contact technical assistance. Do not use with a damaged plug or lose power outlet.
- The robot charger should not share an AC plug point with any other devices. Do not use more than one charger per AC plug.
- Do not charge frozen batteries.
- Do not unplug by pulling on the cord. To unplug, grasp the plug and not the cord.
- Do not replace the battery without contacting authorized distributor center.
- Do not expose the battery charger/ docking station to high temperatures or allow moisture/ humidity of any kind to come in contact with the battery charger/ docking station.
- Do not leave the battery to charge unattended/ overnight as a safety precaution for AGM/ GEL batteries. Unplug the charger after the charging is complete (a typical full charge cycle takes about 8-10 hours).



DANGER



- Do not mutilate or incinerate batteries as they will explode at high temperatures.
- Do not attempt to open the battery charger/ docking station. Repairs should only be carried out by a qualified service personnel.



- Unplug the battery charger/ docking station from the outlet when not in use and before servicing.



- Do not charge the robot if it is wet.
- Do not use outdoors or on wet surfaces.



WARNING



- Install the battery charger in a location that can be easily accessed by the robot. Away from water, on a flat surface and elevated.
- Do not pull or carry by the cord, use the cord as a handle, close the door on the cord, or pull the cord around sharp edges or corners. Keep the cord away from heated surfaces.
- Never smoke in the machine's vicinity while the batteries are charging.
- Use only a compatible battery charger with purchased batteries.



- The charger surface becomes hot while charging.

USING THE REXSCRUB



DANGER



- Immediately discontinue use if anything unusual is noticed during use, recharging, or storage such as noise, smoke, odour, etc. Failure to do so may result in fire, injury, electric shock, damage, malfunction, overheating, leakage, chemical explosion, or other damage to the machine, battery charger and docking station.
- Report machine damage or faulty operation immediately.
- Use the machine within an ambient temperature range of 0°C to 40°C, humidity of 10% to 80%. Also, store in a dry environment with no dust in an ambient temperature range of 0°C to 40°C. Failure to do so may result in fire, injury, electric shock, damage, malfunction, overheating, leakage, chemical explosion, or other damage to the machine, battery charger, battery or docking station.
- In the event of danger, promptly activate the emergency stop push-button to immediately stop all robot motion.
- In areas where the machine is inoperable or unmovable due to power not turning on, move the machine to a safer location.
- **If wearing an implanted cardiac pacemaker or implanted defibrillator, consult with the manufacturer of such medical device to confirm a safe operational distance from the machine.** Electric signals may affect the operation of the pacemaker or defibrillator.



- **Do not use in a healthcare environment or near electronic medical devices.** *The machine does not comply with UL or IEC 60601 standards (or equivalent standards).
- Flammable materials can cause an explosion or fire. Do not use flammable materials in tank(s).
- Do not use the robot in a potentially combustible atmosphere (such as near dusty areas, candles, desktop lamps or a fireplace).
- Do not use the robot to collect gases, explosive/ flammable liquids or powders, nor acids or solvents – including gasoline, paint thinners, acetones, aluminium and magnesium powders.
- Do not operate machine in environments requiring fail-safe performance (areas where machine failure could lead to personal injury or property damage).
- Do not block the machine's ventilation vents. Doing so may cause fire, injury, electric shock, damage, malfunction, overheating, leakage, chemical explosion, or other damage to the machine, battery charger.



WARNING



- Machine can only be operated by trained and authorized users. Operator must be mentally and physically capable of following machine instructions. Operator must read and fully understand the manual.
- This machine is for dry use only. On floors with hard surfaces of 0 % incline.
- Use and store only indoors (i.e., in an enclosed and covered environment).
- Always operate machine in manual mode when going into elevators or through automatic doors, transport loading and unloading. Robotic routes should never include going into elevators or through automatic doors.
- Use robots only in environments, with minimal glare. Do not expose robot to direct sunlight, light sources or environments with high brightness and reflectivity.



- In the event of a fire, use a fire blanket, powder or carbon dioxide extinguisher. Do not use water.
- Do not handle the robot or charger with wet hands.



- Do not operate the robot if it has been damaged in any way.
- Do not operate in a very crowded location
- Do not allow children to play with the robot unattended.
- Do not allow unauthorized persons near the machine.
- Do not operate on slopes or uneven terrain or low traction environments (ice, oil, etc..)
- Do not attempt to ride, climb or sit on machine or allow machine to be used as a toy, transport or any other function other than its intended purpose in this manual.
- Do not leave electrical cords or low-profile items (anything having a height of less than 10 cm from ground) in area of machine operation.
- Do not use ladders, scaffolds, or other temporary constructed structures in area of machine operation.
- Do not block machine vents, otherwise machine shall over heat.



- This machine may be equipped with technology that automatically communicates over the cellular network. If this machine will be operated where cell phone use is restricted because of concerns related to equipment interference, please contact a Lionsbot representative for information on how to disable the cellular communication functionality.
- This machine is **not suitable** for picking up hazardous dust.



CAUTION



- This machine is for indoor use only.
- Avoid operating the robot in places/ times frequented by elderly visitors, general public for noise hazard concerns.
- Exercise caution when running the robot autonomously near visually impaired persons.
- Always keep your eyes on the robot when controlling it via remote control.
- If Operator is allergic to rubber or metal. Gloves must be worn when operating machine.



- Do not leave the robot unattended and stationary in a public area.



- Check the clean water and recovery tanks' water levels when turning the robot on or off.
- Check the battery level of the robot regularly.
- Check that the LIDARs and cameras are clean and dry before starting.
- Follow mixing, handling and disposal instructions on chemical containers.
- Place proper floor cleaning signage in areas where the machine is operating and people are present, in accordance with standard floor cleaning practices.
- Follow site safety guidelines concerning wet floors.
- Operator cooperation is paramount for accident prevention; most workplace accidents are caused by a failure to adhere to safety regulations. An attentive and careful user is the most effective guarantee against accidents.



- Do not operate near cliffs, escalators, stairs or moving platforms in an area of machine operation. Near is defined as 3x robot length or 5 m.
- Do not drive the robot over/down steps or curbs higher than 2cm.
- In manual mode, do not operate the robot over uneven surfaces and steep slopes more than 10 % grade (6 degrees).
- In autonomous mode do not operate on slopes, the floor must be flat.
- Do not use any acidic, strong solvents, chlorine based and flammable chemicals.
- Do not press the ultrasonic sensors.
- Do not put any weight on the robot. Do not stand on the Squeegee assembly.
- Do not use the robot to pick up anything that is burning, such as cigarettes or matches.

STATUS MONITORING SYSTEM

REXSCRUB is equipped with a status monitoring system. This system acts as a secondary channel for the robot's navigation related safety system. The system receives a heartbeat status signal from the computer at a pre-defined frequency (2Hz). The systems only unlock the power to the traction motors and other moving parts such as brush motors & vacuum motors if the heartbeat is regularly updated. This ensures that the robot cannot move if the IPC (Industrial PC) is switched OFF or spoilt half-way through the autonomous or manual operation.

This system is to prevent REXSCRUB from moving on its own without receiving correct instructions from on-board computer.

DEACTIVATION AND STORAGE



WARNING



- Store the robot in a dry, sheltered place.
- Stop the robot on a flat surface. Turn the key switch off and remove the key.



- Do not store the robot near combustible materials.

CLEANING AND MAINTENANCE



WARNING



- Do not spray water directly at the robot to clean it.



- Do not use chemicals such as benzene, thinner, acetone or alcohol to clean the robot.
- Do not attempt to modify, disassemble or repair the robot. Repairs should only be carried out by a qualified service personnel.



- Stop robot on a level surface. Turn off robot and remove the key before cleaning or activate E-STOP before maintenance of the robot to prevent activation.
- Wear personal protective equipment as needed and where recommended in this manual.
- Avoid moving parts. Do not wear loose clothing, jewellery and secure long hair.
- Block machine wheels before jacking.
- Jack machine up at designated locations only.
- Use hoist or jack that will support the weight of the machine.

TRANSPORT



CAUTION: The REXSCRUB can be only be moved when powered manually. When moving around narrow areas e.g., corridors, use manual mode only.

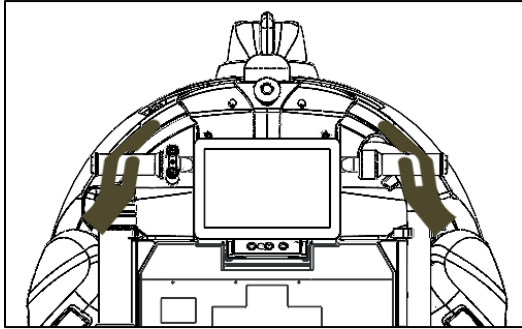

Fig. 1

- Turn on the key switch and Login with your user ID and password.
- Moving the REXSCRUB manually: place both hands on the handle bar, twist the throttle to move forward (Fig. 1).
- Press and **HOLD** the reverse button and twist the throttle to reverse (Fig 2).
- Use Manual mode to Move the REXSCRUB into lifts or loading: in reverse/forward (Fig 3 & Fig 4).



NOTE:

REX dimensions and turning radius in narrow corridors see [Technical Data'](#).

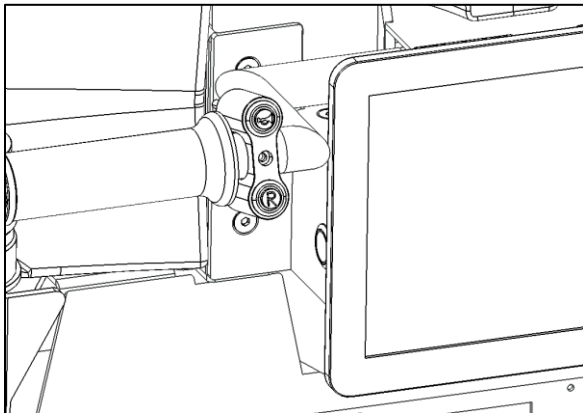

Fig. 2

- Moving over uneven surfaces (humps, steps): in any situation that could cause the REXSCRUB to tilt or tip over an obstacle while moving, always use ramps or use a different path to reach destination.



WARNING: Do not drive the robot over/down steps or curbs higher or lower than 2cm. Check your surrounding environment for hazards (people, slopes, escalators etc.) before moving the robot.

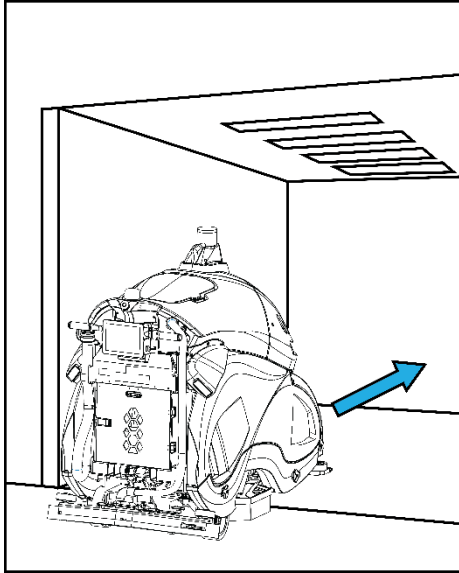

Fig. 3

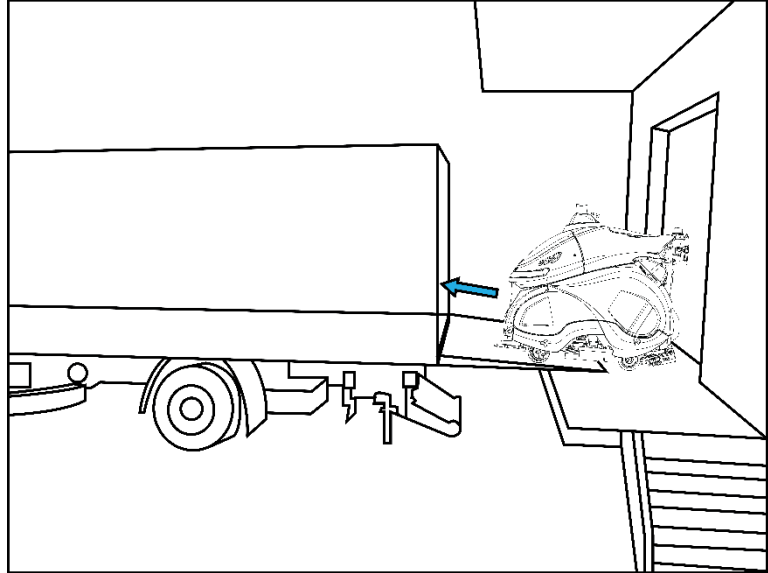

Fig. 4

- Transporting in a truck:

- A minimum of two person shall be responsible of loading/ unloading the Robot at a designated loading/unloading bay.
- Load only on hydraulic ramps of 2.0m x 2.4m, with load carrying capacity of 1500 kg minimum.
- Load robot front in only.
- Drain both tanks before transport.
- Use ramp, truck or trailer that will support the weight of the machine and operator.
- When moving the REXSCRUB onto a hydraulic ramp of a truck, drive in. (Fig. 4).
- Do not load/unload on ramp inclines that exceed 10% grade / 6°.
- Do not drive on a slippery ramp.
- When the REXSCRUB is on the ramp, press the E-stop to prevent it from sliding.
- Block machine tires.
- Lower down the brush and squeegee.
- Keep the E-stop depressed to prevent robot motion during transport.
- Turn off machine and remove the key.
- Use tie-down straps to secure machine. See '[ANCHOR AND JACK POINTS ON REX](#)'



WARNING: The user is at risk of tipping over the robot and subject to crush hazards when loading/ unloading the robot. The operator and spotter are responsible for identifying and mitigating loading/ unloading hazards and taking safety precautions.



REMOVING THE SIDE PANELS

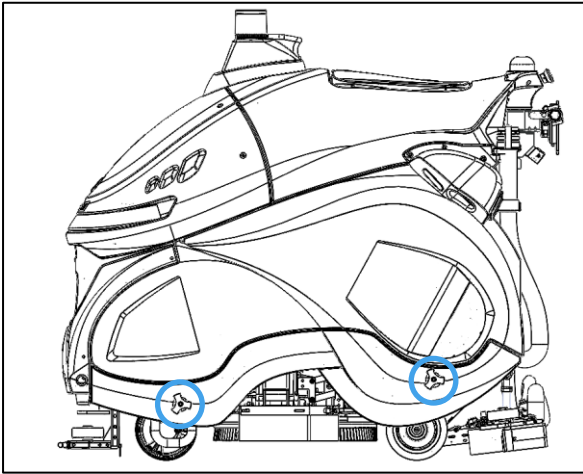

Fig. 1

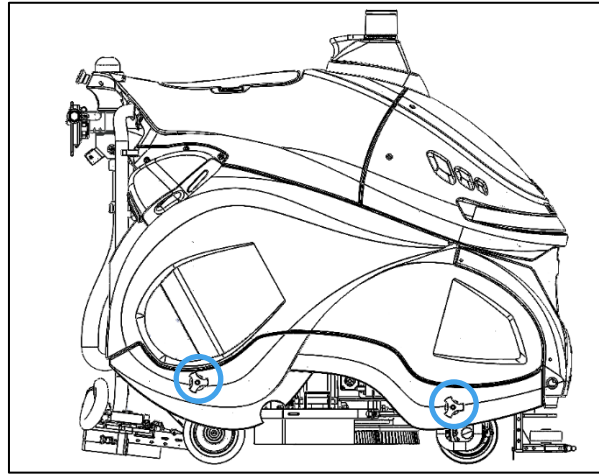

Fig. 2

1. Remove left side panel covers on the REX by turning the blue knobs shown (Fig 1).
2. Pull panel out, the panel accommodates a small amount of flex.
3. Remove right side panel cover on the REX by turning the blue knobs (Fig 2).
4. Pull the panel out.
5. Place panels in a secure location.

ANCHOR AND JACK POINTS ON REX

The following image shows the location of the anchor and jack points on the REX.

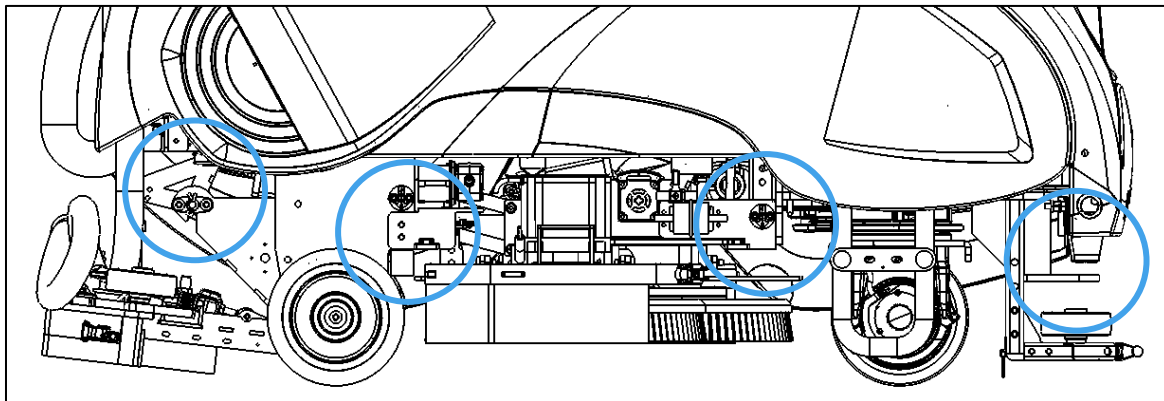

Fig. 1

The following images show the anchoring points on the REX



Fig. 2

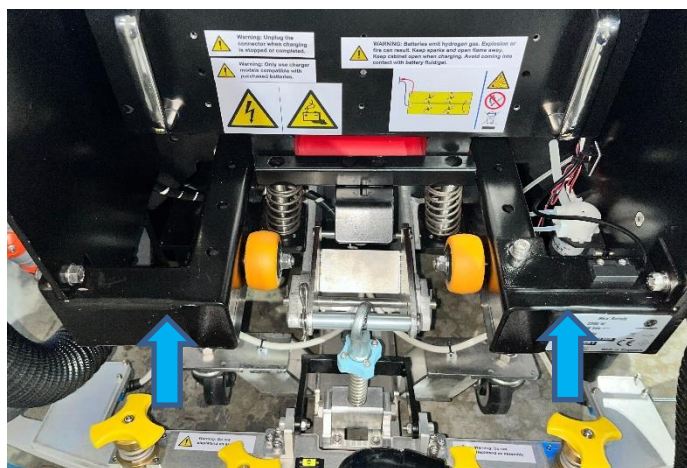

Fig. 3

The following images show the jack point on the REX.



Fig. 4

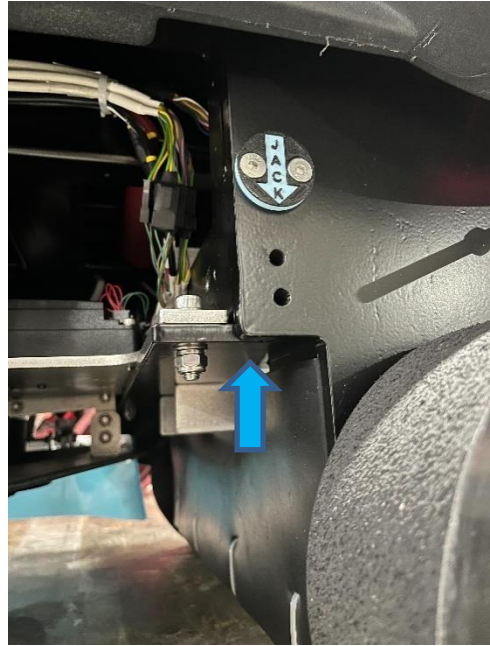

Fig. 5



Fig. 6

DISPOSAL



NOTE: Due to the presence of toxic or harmful materials inside the REXSCRUB (e.g., batteries, IPC), the robot should not be left unattended at the end of its working life. See section on '**DISPOSAL**' for instructions on scrapping.

EMERGENCY STOP ACTIVATION



WARNING:

- If you anticipate any imminent danger to the REXSCRUB or its surroundings, or in operating the robot in any novel situation, always be on standby to trigger the emergency stop button directly on the robot (see the section on '[EMERGENCY STOP](#)' for details on usage).
- After the Emergency stop button is pressed, all of robot motor operations will stop immediately, cleaning functions and traction motor will cease operation. The LED lights will flash RED.
- Before resuming normal operation, the operator must check the robot's condition and surrounding for safety.
- Robot will not resume previous operation after ESTOP is released and Reset button is pushed. The Operator needs to restart the previous operation using the touchscreen or LionsClean App.







WARNING ON NOISE LEVEL



WARNING: REXSCRUB noise level is about 69dB during cleaning operation.

NAME PLATE

The serial number sticker is located on the robot back. Please provide this serial number along with any request for assistance/ servicing or spare parts purchase.

| | | |
|---|---|---|
| REXScrub | |  LIONSBOT |
| Power | 2200 W | |
| Voltage | 36 V dc  |    |
| Max Weight | 690 Kg | |
| S/N: REX-210001-SCR | |   |
| P/N: REXSCR-1 | | |
| 11 Changi South Street 3 #03-02 Singapore 486122 | | MADE IN SINGAPORE |

The Serial Number is formatted as follows:

1. First three Alphabets (REX).
2. Last four digits (YY-0001) encode the year and sequential number of the product
3. Next three alphabets (SCR) denote the product type.

SYMBOLS ON THE REXSCRUB

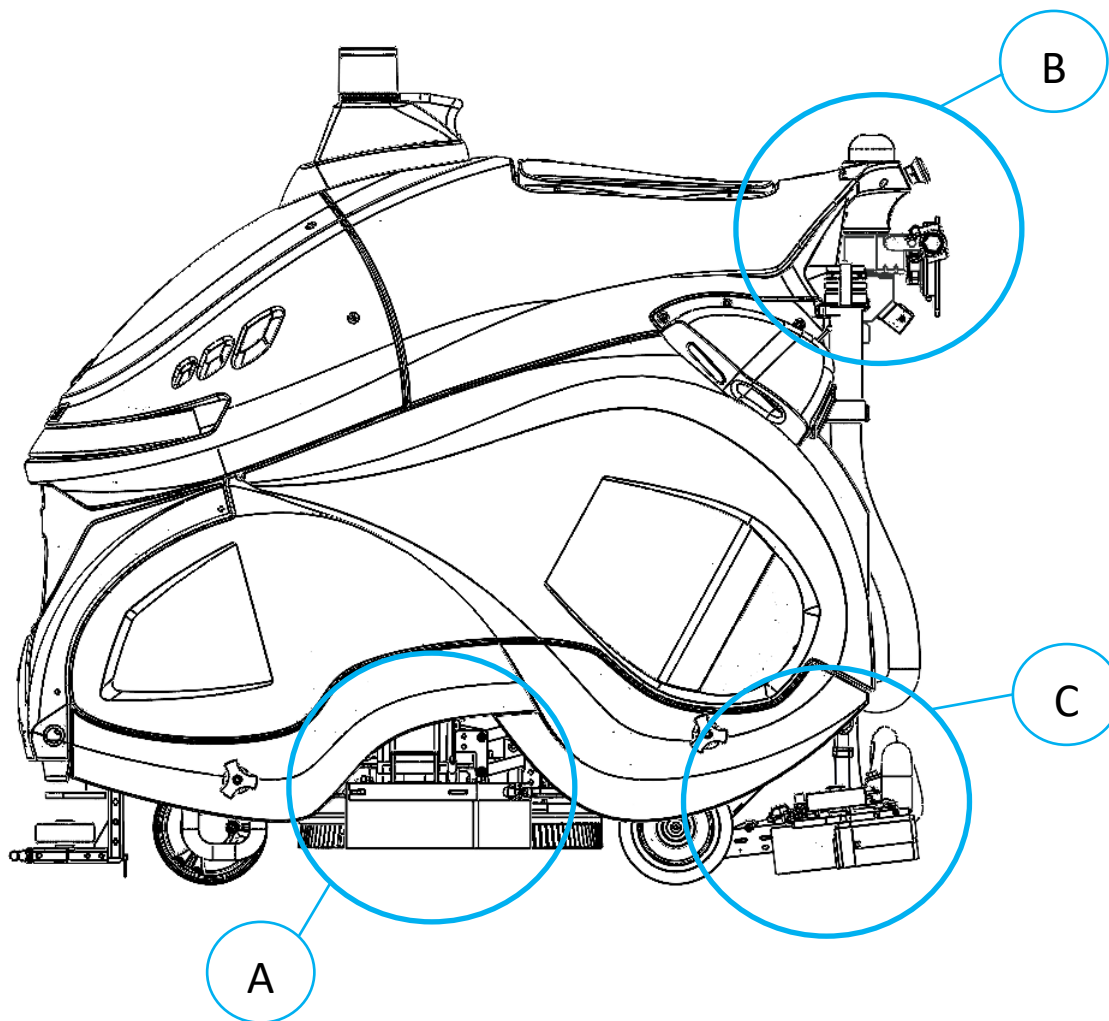

A

 **WARNING**
CRUSH HAZARD
Keep hands and feet away from wheels.

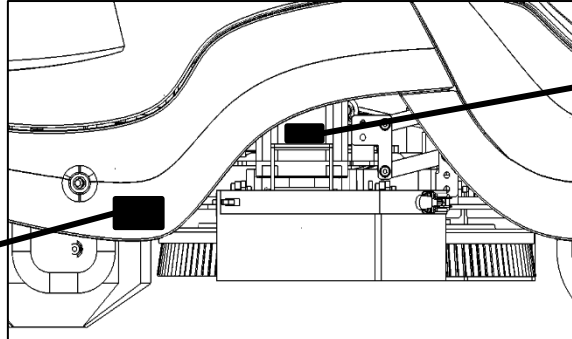

 **Warning: Activate the emergency stop when servicing the machine.**

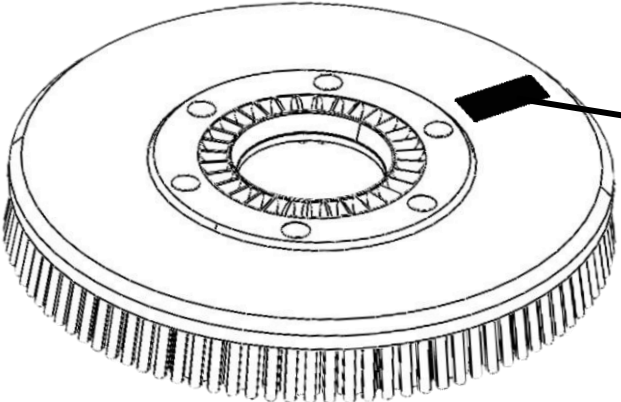

 **WARNING**

Magnetic Field.
Can be harmful to pacemaker implant.  
Persons with a pacemaker stay back 90 cm. (36 in.)

B

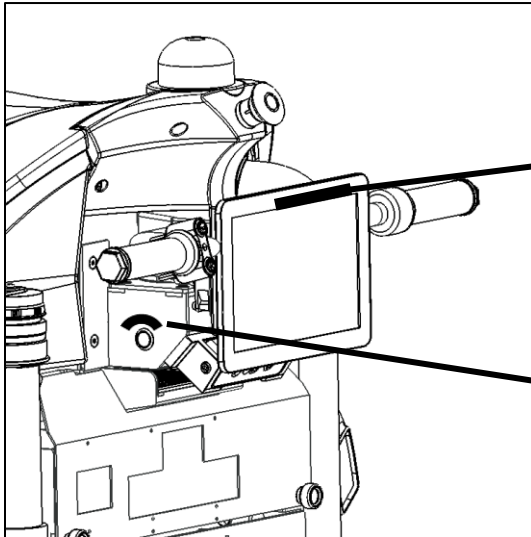

  Read and fully understand operation manual before using



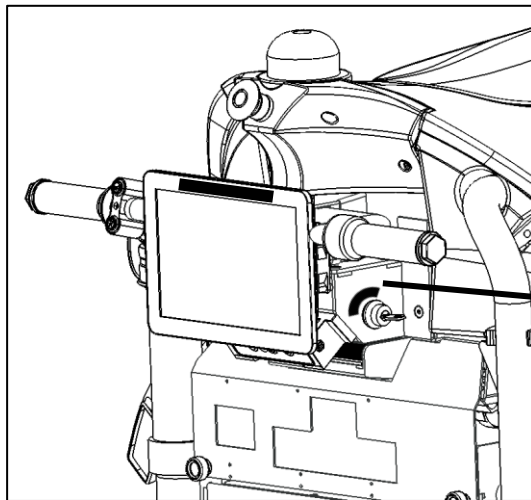

Reset Button – Reset safety

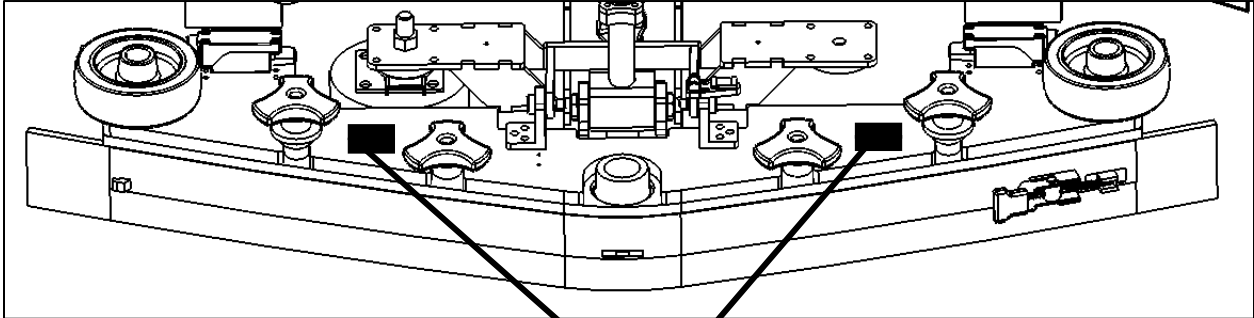

Off/On Button

C



 **Warning: Do not step/stand on assembly.**

WARNING

- Unplug the connector when charging is stopped or completed.
- Only use charger models compatible with purchased batteries.
- Batteries emit hydrogen gas. Explosion or fire can result.
- Keep sparks and open flame away.
- Keep cabinet open when charging.
- Avoid contact with battery fluid/gel.

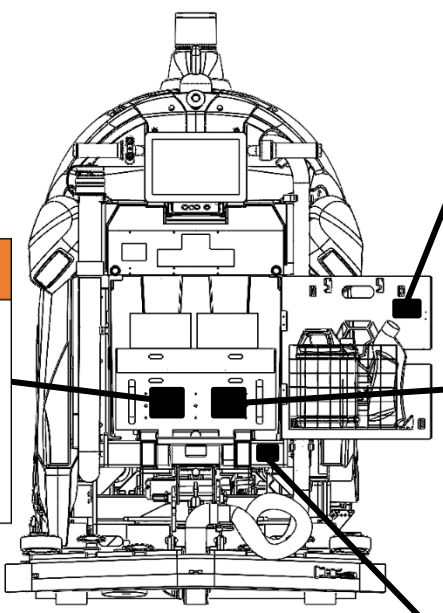
 **Warning: Flammable materials can cause explosion or fire. Do not use flammable materials in tank.**

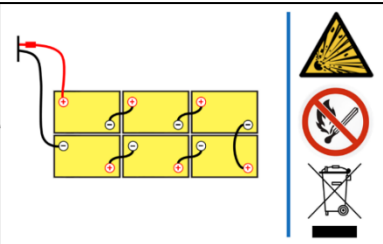

REXScrub

Power 2200 W
 Voltage 36 V dc
 Max Weight 690 Kg

S/N: REX-210001-SCR
 P/N: REXSCR-1

11 Changi South Street 3
 #03-02 Singapore 486122

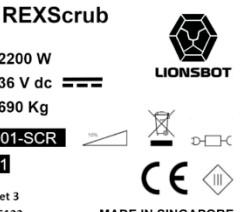

MADE IN SINGAPORE

TECHNICAL DATA

| Technical Data | SI [KMS] | Value |
|---|-------------------|-------------------|
| Rated machine power | W | 2200 |
| Working capacity ⁵ | m ² /h | 4080 |
| Working width | mm | 810 |
| Squeegee width | mm | 950 |
| Brush head brushes/pads (number –external Ø) | No./ mm | 2/406 |
| Brush RPM | Rpm | 200 |
| Brush head motor (voltage – nominal power rating) | V /W | 36V/450 |
| Maximum weight exerted on brush head | Kg | 80 |
| Battery (nominal voltage –capacity) ⁴ | V/Ah | 36/310 |
| Traction motor (voltage – rated power) | V/ W | 36/600 |
| Traction wheel (external Ø - width) | mm/mm | 200/60 |
| Maximum slope during ascent and descent during transport ⁽²⁾ | %/° | 10.5/6 |
| Maximum ambient temperature for machine operation | °C | 40 |
| Minimum temperature for using the scrubbing function | °C | 0 |
| Rear wheel (external Ø - width) | mm/mm | 200/70 |
| Maximum forward speed during transport (manual) | m/s | 0.7 |
| Maximum forward speed during cleaning (autonomous) | m/s | 1.4 |
| Maximum reverse speed | m/s | 0.3 |
| Vacuum motor (voltage - nominal power rating) | V / W | 36/550 |
| Maximum clean water tank capacity | L | 140 |
| Maximum recovery tank capacity | L | 140 |
| Chemical bottle capacity ⁽¹⁾ | L | 5 |
| Defoamer bottle capacity | L | 1 |
| Turning radius | m | 2.50 |
| Three points turn minimum corridor width | m | 2.15 |
| Robot dimensions (length – width - height) | mm | 1675 x 890 x 1473 |
| Robot weight during transport ⁽²⁾ | kg | 366.5 |
| Robot weight during cleaning ⁽³⁾ | kg | 689.5 |
| Sound pressure level | dB | 75.1 |
| Maximum altitude | m | 2000 |
| Storage temperature with tanks and hoses empty | °C | -20 to 45 |
| Storage humidity | %RH | 20 to 93 |

(1) For standard chemical bottle

(2) Both tanks empty and without batteries

(3) Clean water tank full and with batteries (Gross Vehicle Weight)

(4) Capacity dependent on batteries purchased, see battery datasheet for specification.

(5) Calculated based on cleaning in a straight Working capacity dependent on battery capacity, which can reduce over time.

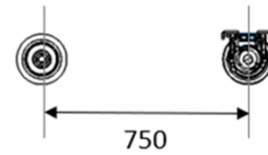
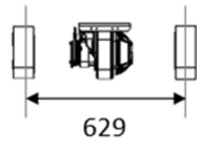
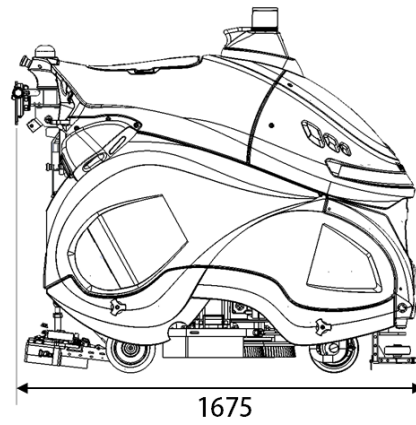
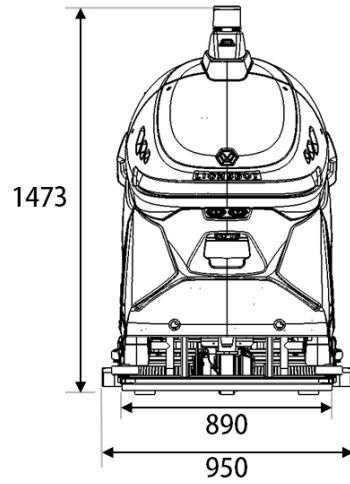

HUMAN SAFETY FEATURES OF THE REXSCRUB

Distance sensors, safety bumpers and obstacle avoidance behaviors are paramount to the safety of people and objects around the REXSCRUB, and the REXSCRUB itself. These features are described below to better equip the user for safe and productive working with the REXSCRUB.

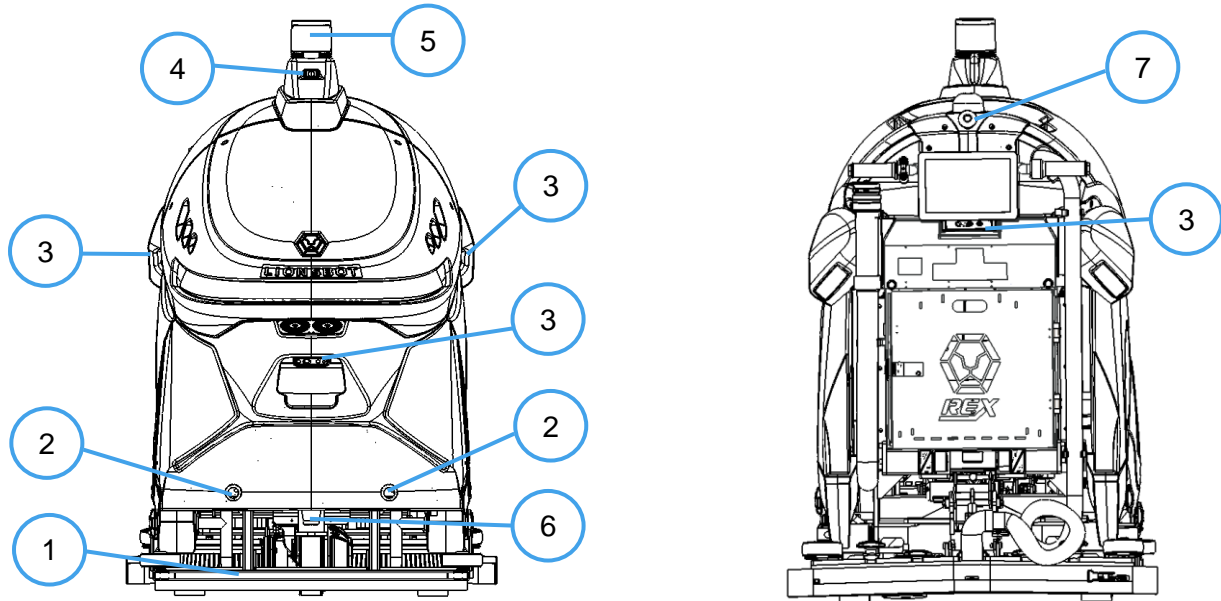

Fig. 1

- 1. SAFETY BUMPER
- 2. SONARs
- 3. DEPTH CAMERA
- 4. RGB CAMERA

- 5. 3D LIDAR
- 6. 2D LIDAR
- 7. EMERGENCY STOP

DISTANCE SENSORS

1. LIDAR

The 3D/2D LIDARs provide distance measurements to objects or features in front and at the back of the REXSCRUB. The front LIDAR is located at the base of the REXSCRUB above the bumper (Fig. 1 – 2), and the top LIDAR near the recovery tank hatch (Fig. 1 – 1).

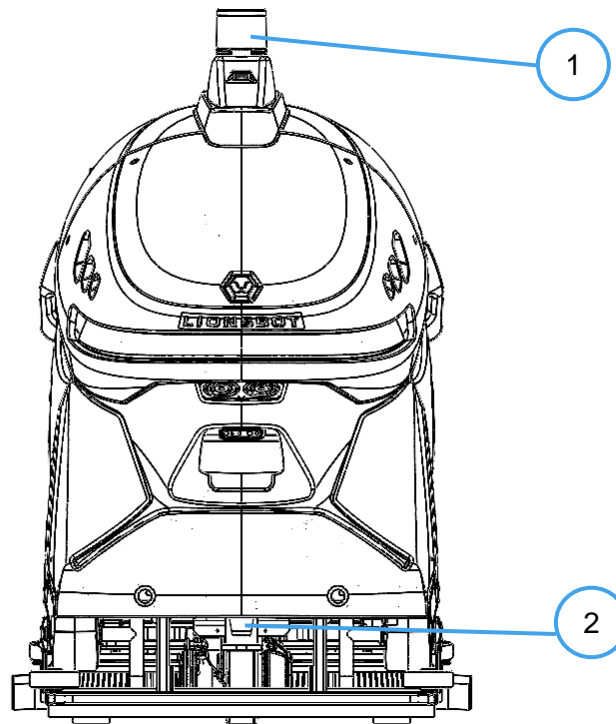

Fig. 1



WARNING: The LIDAR does not work with glass and performs poorly with reflective surfaces and black surfaces. Do not attempt to run robot autonomously in areas with glass and reflective and black surfaces.



NOTE: As the LIDAR operates in the Infrared region, the REXSCRUB can be operated at night. The Table below and Fig. 2 illustrate the field of view of the front and rear LIDARs.

| Technical Data | Unit | Value |
|---------------------------------|------|-------|
| 3D Lidar Field of Vision | ° | 360 |
| up- Plane | ° | 15 |
| down | ° | 45 |
| Effective Radial Range | m | 100 |
| 2D Lidar | ° | 180 |
| Effective Radial Range | m | 20 |
| Height above ground | cm | 18 |

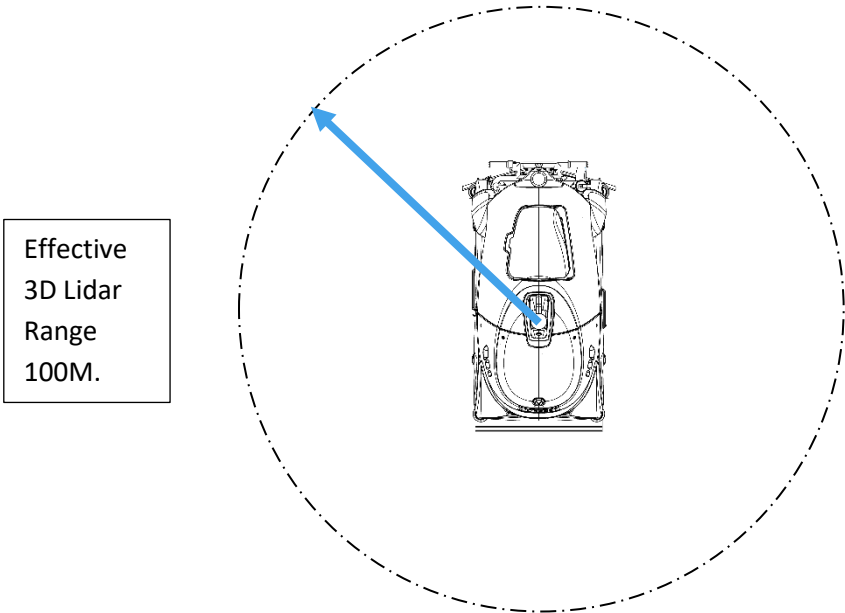

Fig. 2

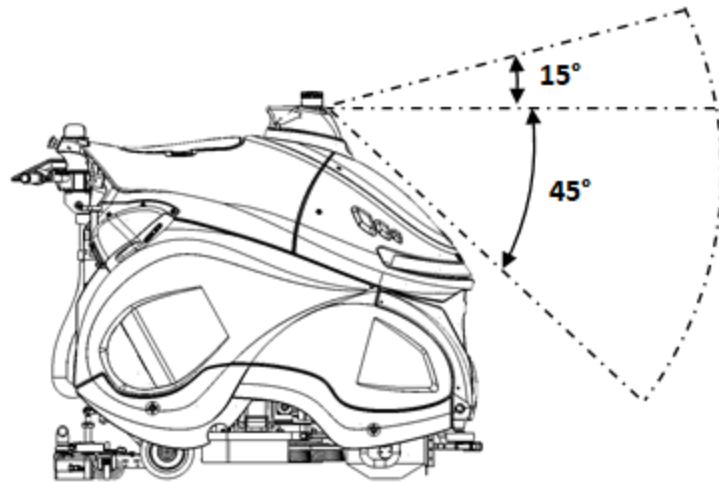

Fig. 3

2. SONARs

The SONARs supplement the LIDARs by measuring distance to obstacles close to the body of the robot, in their line of sight (about 27.5 cm above the ground plane). The REXSCRUB is equipped with four sonars on the periphery of the bumper (Fig.3,4, & 5, blue circle highlighted).

| Technical Data | Unit | Value |
|-----------------------------|------|-------|
| Sonar array Field of Vision | ° | 180 |
| Effective Range | m | 0.9 |
| Height above ground | cm | 27.5 |

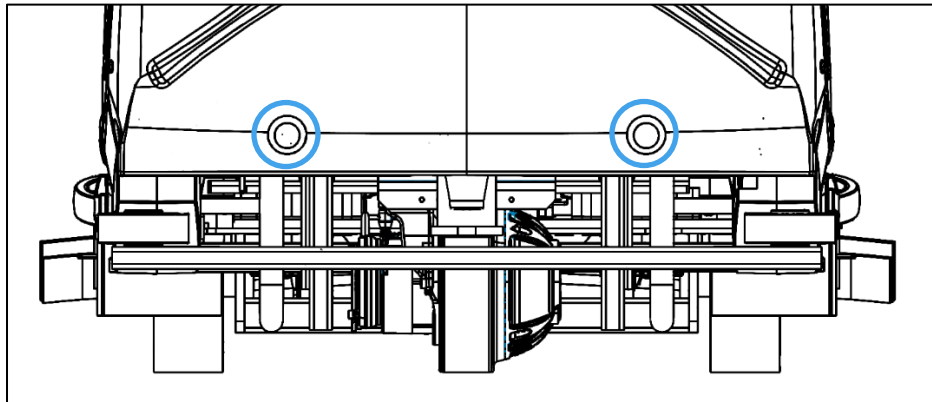

Fig. 3

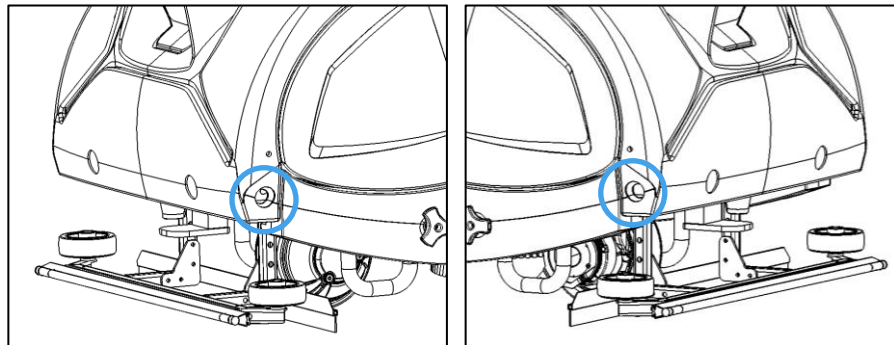

Fig. 4

Fig. 5

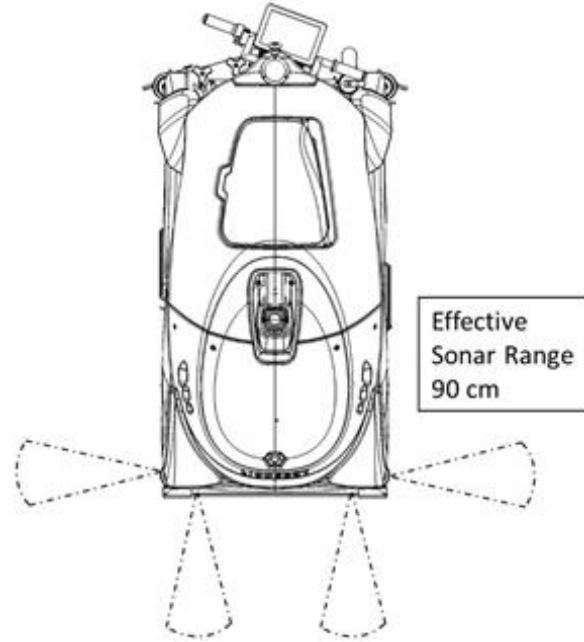

Fig. 6

3. DEPTH AND RGB CAMERAS

The cameras also supplement the LIDARs in helping the REXSCRUB gauge the distances to objects in front of it. It is equipped with depth sensors and an RGB sensor. It is placed on the front of the robot (Fig. 7), sides (Fig. 8 & 9) and back (Fig. 10). Note that it does not record pictures of the scene (Fig 11, 12 Cameras field of view).

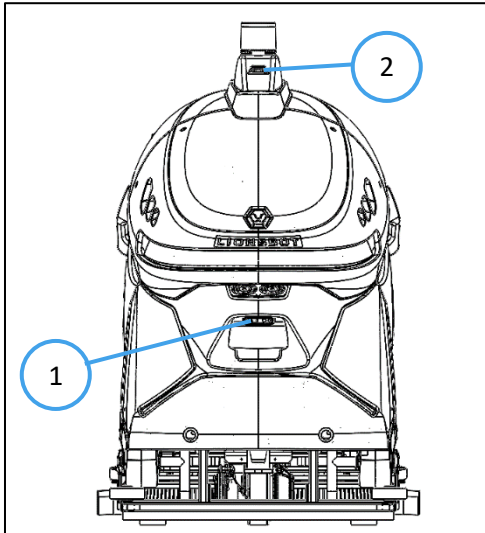

Fig. 7

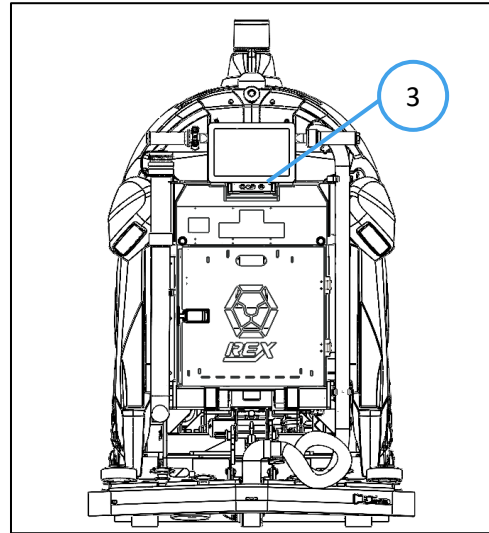

Fig. 8

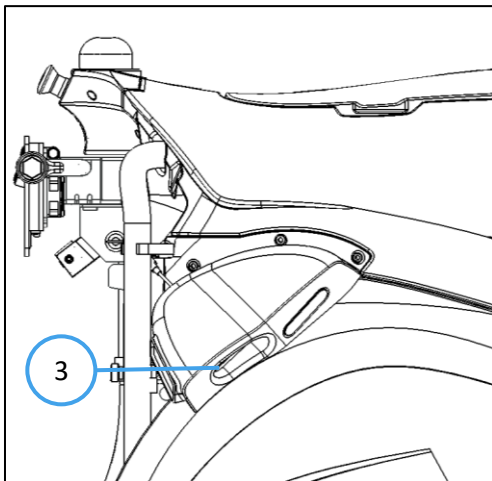

Fig. 9

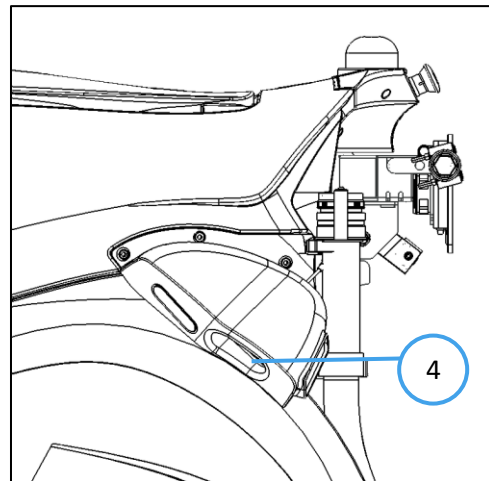

Fig. 10

| Technical Data | Unit | Value |
|------------------------------|------|-------|
| Front Camera field of vision | ° | 72 |
| Top Camera field of vision | ° | 126 |
| Side Camera Field of Vision | ° | 60 |
| Back Camera Field of Vision | ° | 60 |
| Front Camera Effective Range | m | 20 |
| Top Camera Effective Range | m | 5 |
| Side Camera Effective Range | m | 3 |
| Back Camera Effective Range | m | 20 |

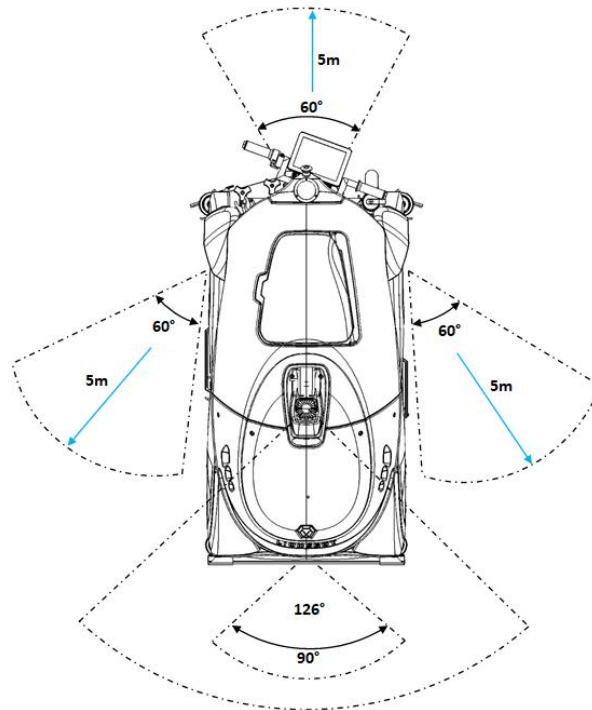

Fig. 11

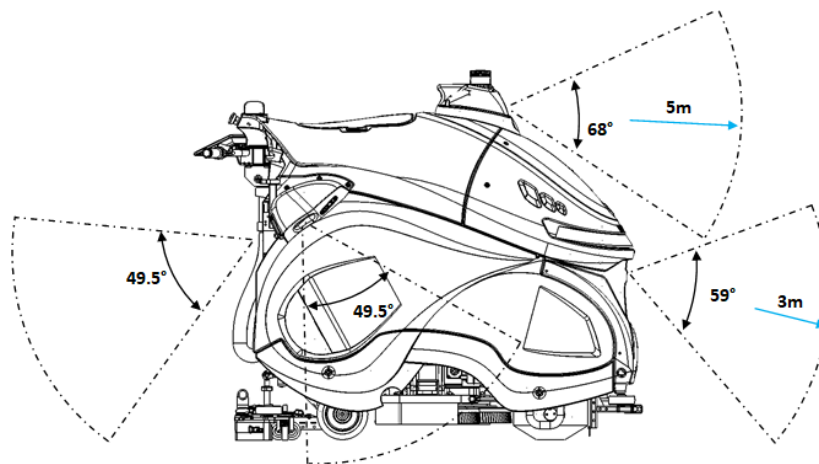

Fig. 12

SAFETY BUMPER

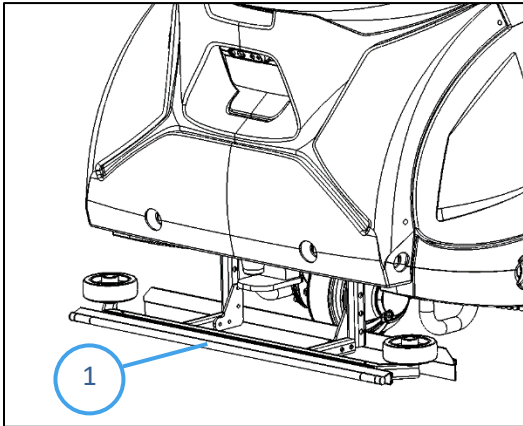

Fig. 1

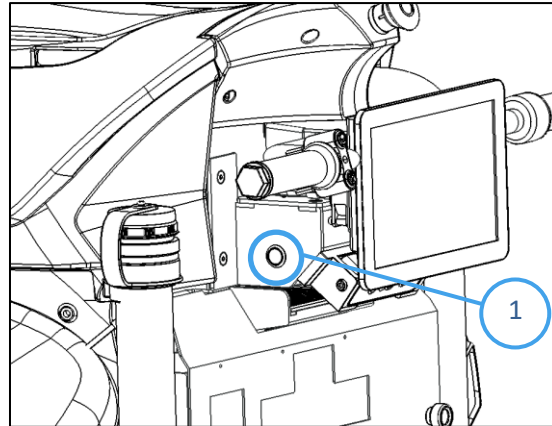

Fig. 2

The REXSCRUB is equipped with a safety bumper (Fig. 1 - 1) at the front. The bumper will trigger when it hits an obstacle, immediately engaging emergency mode:

Emergency Mode

- All movements and cleaning processes will stop.
- The robot's lights will flash red.

Pressing the Reset Button (Fig. 2 - 1) will release the safety bumper (reset the emergency trigger) and the robot will return to a usable state.

To release the safety bumper:

1. Move the obstacle away from the safety bumper.
2. Press the Reset Button (Fig. 2 - 1) to release the safety bumper and the robot will return to a usable state.

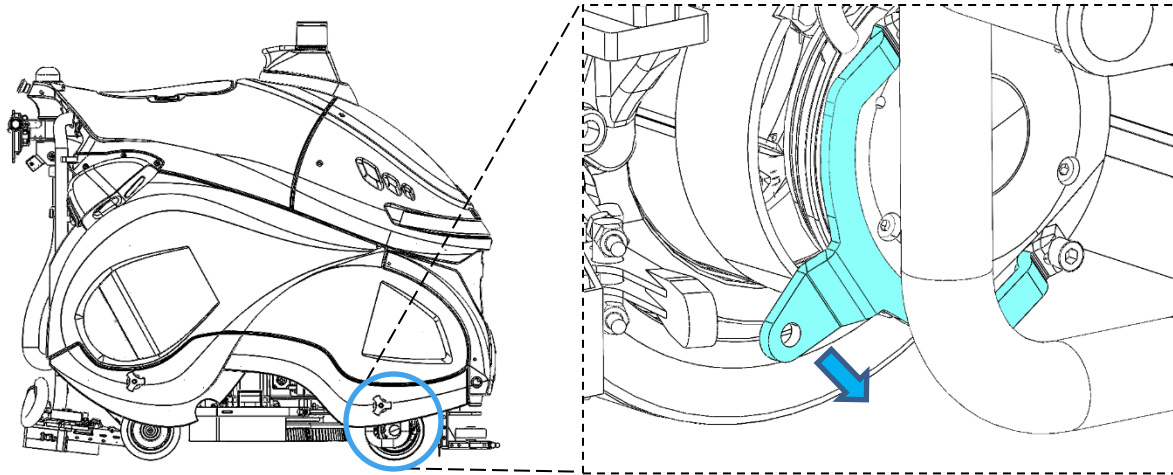

Fig. 3

If the obstacles are fixed or cannot be moved (etc. wall), **Activate the ESTOP first.**

Pull on the brake lever located on the right side of the front wheel (Fig. 3 - 1) and slowly push the robot away from the obstacle. Only push or tow machine for a short distance and for speeds not exceeding 3.2 km/h (2 mph).



WARNING: Do not push or tow machine for a long distance or damage may occur to the propelling system.

Press the Reset Button to unlock the robot motors. If robot can't be moved, use a fork lift, jack or anchor point to remove the robot. See the '[Transport](#)' section on robot anchor/ jack points.

OBSTACLE AVOIDANCE

The robot is equipped with obstacle avoidance behavior as an essential safety feature. When the REXSCRUB encounters an obstacle, it automatically decelerates and waits to see if it moves away, and if it doesn't, the robot tries to plan a new path for its cleaning.

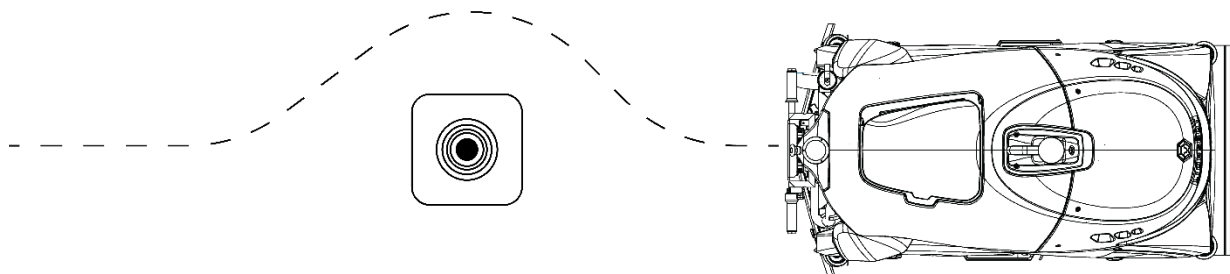

EMERGENCY STOP

The emergency stop can be activated to immediately stop all robot motion and activity:

1. A red emergency button is located at the back of the robot (Fig. 1 - 1).
2. Depressing this button cuts off power to the internal motors of the robot (movement and cleaning are cut-off), after which all lights on the REXSCRUB blink red. This indicates the robot is in an emergency mode.
3. To recover from emergency mode, reset the Emergency Stop button by turning it clockwise. The button pops out on reset.
4. Press the reset button on the left side of the robot to exit Emergency Mode. Upon successful recovery, LEDs will stop flashing red.

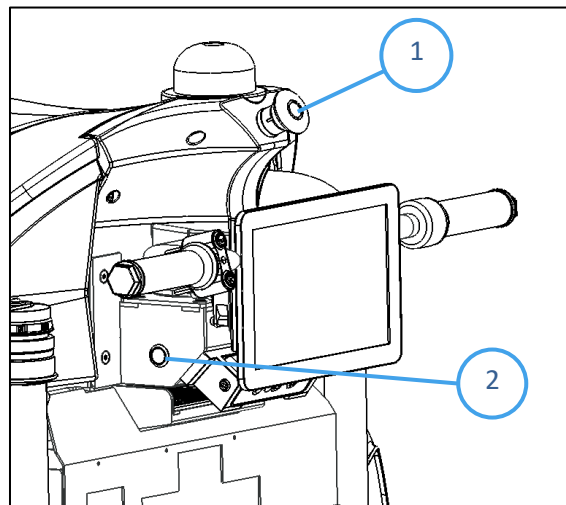

Fig. 1

PERSONALITY OF THE REXSCRUB

The physical user interface of the REXSCRUB – including LED lights, and speakers - imparts it the personality of a productive cleaning companion.

LED LIGHTS

The REXSCRUB is equipped with LED light panels on the front and sides. The LED lights help to convey various state of the robot – for example, when the robot is under emergency stop, all the lights blink red.

RECEIVING AND PREPARING THE REXSCRUB

The REXSCRUB ships with the brushes and squeegee assembly detached from the body. Some accessories are also included to facilitate charging and maintenance operations.

HANDLING THE PACKAGED ROBOT

The robot's overall packaged weight is 533kg.

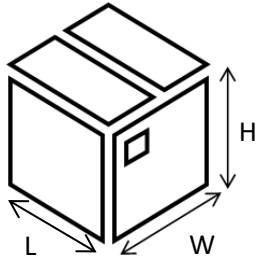

| | |
|----------|---------------|
| L | 184 cm |
| W | 106 cm |
| H | 152 cm |

It is recommended to keep the packaging components for future transportation needs.

UNPACKING THE ROBOT

1. Open the crate and take off any protective packaging material around the robot.
2. Verify the package contents against the following packing list:

| ITEM | QTY |
|---------------------------------------|----------|
| REXSCRUB | 1 |
| Battery Trolley | 1 |
| Trolley Wheels | 4 |
| Handle | 1 |
| Bag Screw, Nuts and Cable ties | 1 |
| Lidar Skin | 1 |
| Lidar Camera Pack | 1 |
| Lidar and Mount | 1 |
| Debris Cage | 1 |
| Dolly | 1 |
| Brush PP 16" | 2 |
| Squeegee with rubber | 1 |
| Squeegee Rubber (Blue)- Front | 1 |
| Squeegee Rubber (Blue)- Back | 1 |
| Mixing Chamber | 1 |
| Battery cable Extension | 1 |
| Battery Cable small | 5 |
| Battery Connector | 2 |
| Brush rubber skirt | 2 |
| Fresh water hose | 1 |

3. Power on the robot as described below ("[POWERING ON/OFF THE REXSCRUB](#)") and pilot it out of the crate in reverse to avoid the risk of tipping.

BATTERY INSTALLATION

Ensure Robot is powered OFF before installing the batteries.

1. Open the chemical cabinet (Fig 1).



Fig. 1

2. Align battery trolley to the battery tray (Fig 2).

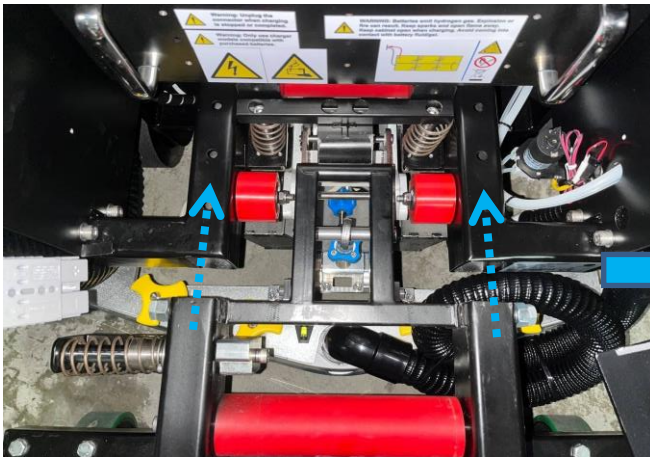

Fig. 2

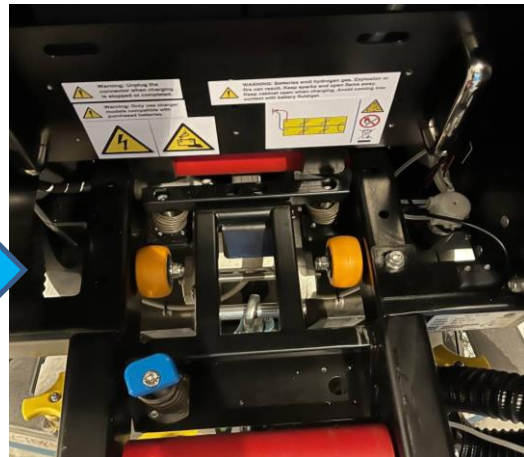

Fig. 3



WARNING: REX SCRUB's tray of batteries is estimated to be 250kg. Changing of batteries should only be done by a trained and qualified technician with the correct set of tools. Do not tamper with or attempt to replace the battery yourself. Contact your local distributor for assistance.

3. Push trolley forward till a 'click is heard' ensuring the trolley is locked to the REX chassis (Fig 3).
4. Lock the trolley wheels then press on the battery tray latch (Fig 4).



Fig. 4

5. Roll out the empty tray onto the trolley until the battery tray latch is secured (Fig 4).
6. Unlock the wheels and Unlatch the trolley from the chassis and move it to load the batteries.
7. Load the batteries into the empty rack.
8. Refer to the connection diagram to connect the batteries (Fig 5).

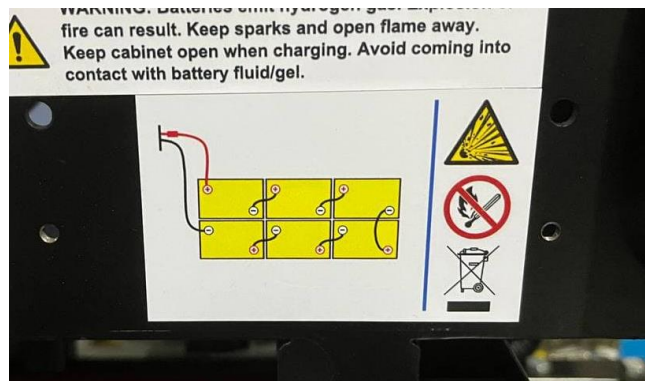

Fig. 5

CHARGING THE BATTERY



Caution:

1. Only use the battery charger provided by an authorized distributor.
2. The robot charger should not share an AC plug point with any other devices.
3. Refer to disposal information for disposal of the REXSCRUB and battery inside.
4. If the battery is not charging, contact the authorized distributor immediately.
5. The following actions must be carried out by qualified personnel.
6. The charger surface becomes hot while charging.



Note: REX SCRUB does not come with on-board charger. Please use the charger provided by the authorized distributor to charge the batteries on the REX SCRUB



Note: Before first use, Users are advised to charge the battery to 100%.

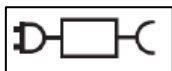

This symbol on the nameplate informs the user to use the robot only with the supported battery charger purchased.

For more **General Safety Information** Refer to section '[CHARGING THE BATTERIES](#)'.

1. The manual charging port (1) is located at the rear of the robot and can be accessed by opening the chemical cabinet (Fig 1).

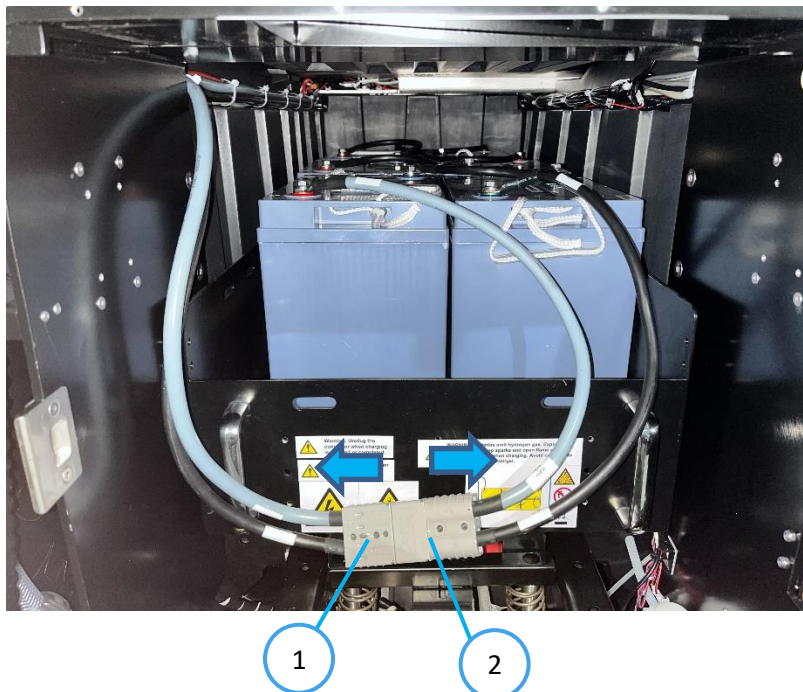

Fig. 1

2. Unplug the machine cable port (Fig. 1 – 1) from the batteries cable port (Fig 1 – 2).

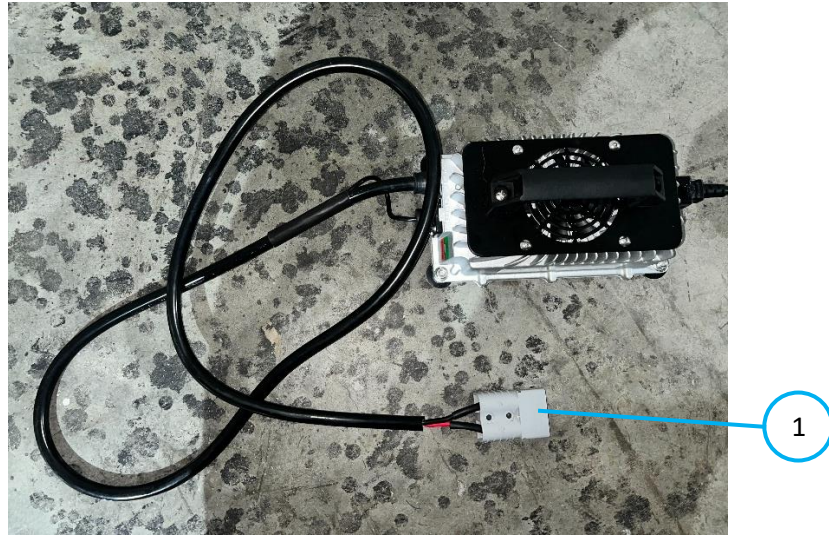

Fig. 2

3. Grab the batteries cable port and plug it into the charger port (Fig. 2 – 1). The cable should fit snugly; it requires some force to be inserted.
4. Turn the charger on.



A typical full charge cycle takes about “8 – 10 hours”, dependent on charger and batteries.



DANGER: Hydrogen gas might build up during charging. Leave the chemical cabinet open when charging for good ventilation. Charge batteries in a well-ventilated room.

5. When charging is finished, the battery charger will display 0A. Then, turn off the charger.
6. Charge the battery daily after usage to prevent over-drainage of the battery.
7. The REXSCRUB uses AGM batteries only. Charge according to battery manufacturer’s instructions.

POWERING ON/OFF THE REXSCRUB



NOTE: This power switch is cutting off positive power line from battery to the circuits when power switch is at off position.

To power on:

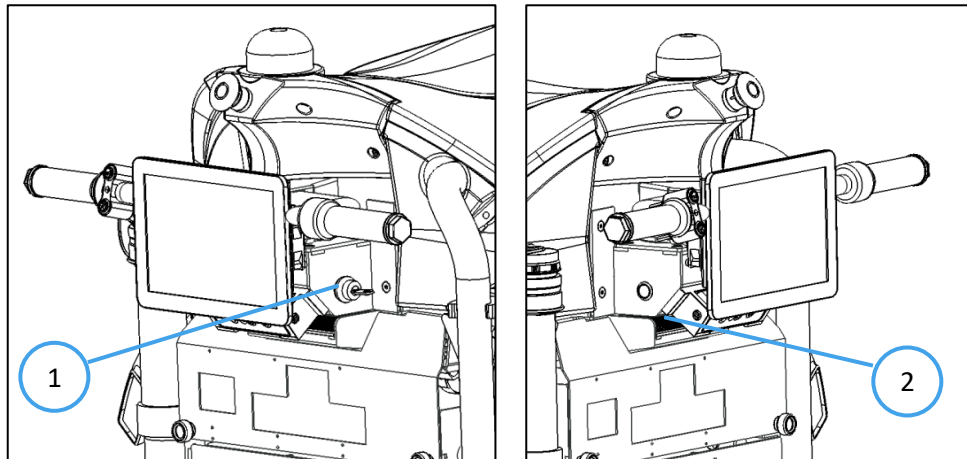

Fig. 1

Fig. 2

1. Insert Key into switch as shown (Fig. 1 -1).
2. Turn the key switch to the 'ON' position. The key cannot be removed from the switch when it is 'ON'.
3. Push the RESET button (Fig. 2 - 2) to the left of start panel; the robot LEDs will turn blue, and a 'Engine' sound will be heard indicating startup.

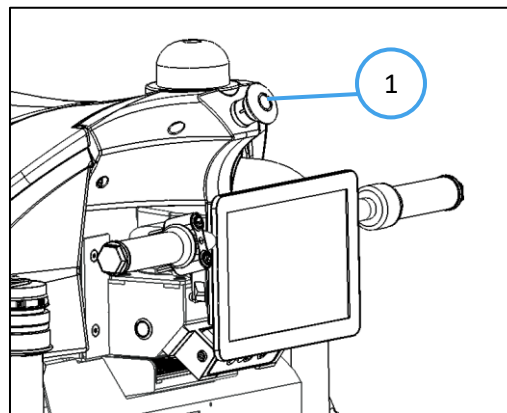

Fig. 3

4. Ensure the E-Stop (Fig. 3 - 1) is released. If the E-Stop is engaged, the LEDs will be red. Refer to "[EMERGENCY STOP](#)" on deactivation.

To power off:

1. Turn the key switch to the 'OFF' position.

BRUSH ASSEMBLY

1. If necessary, Detach the side panels to access the brush clutches on the underside of the robot as described in '[PREPARING TO WORK WITH THE FLOOR TOOL](#)'.
2. Lift the rubber guard for easier access/ better viewing angle of the magnetic clutch (Fig 2-1).

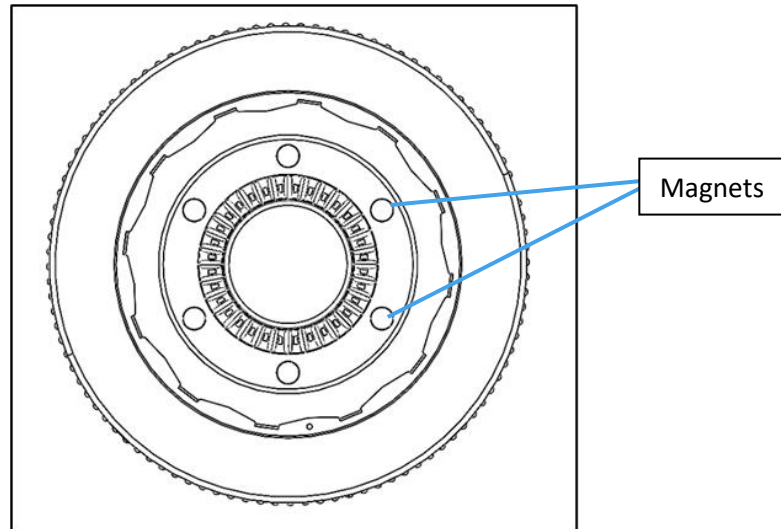

Fig. 1



Danger: Magnets may interfere with pacemakers and other medical devices. Do not change brushes if operator has field sensitive devices.

3. Slide the brush under the robot and align it with the clutch (Fig 2).

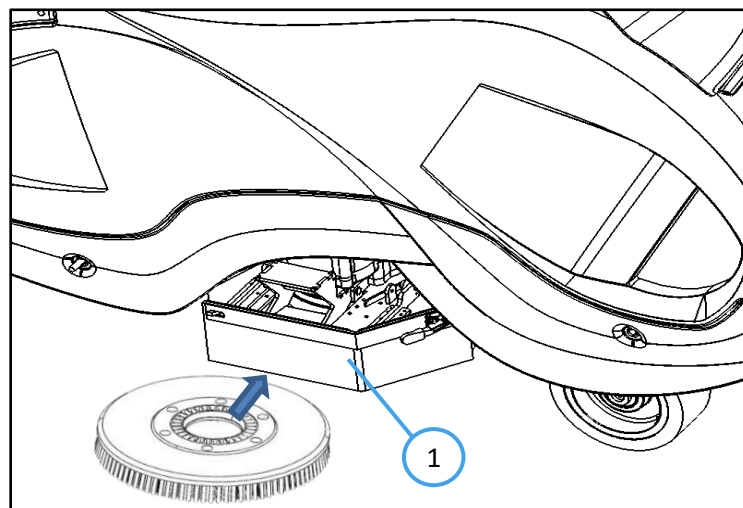

Fig. 2

4. Hold the brush up towards the clutch, the magnets on the brush will be attracted towards the magnetic clutch and slot into place (Fig 3).

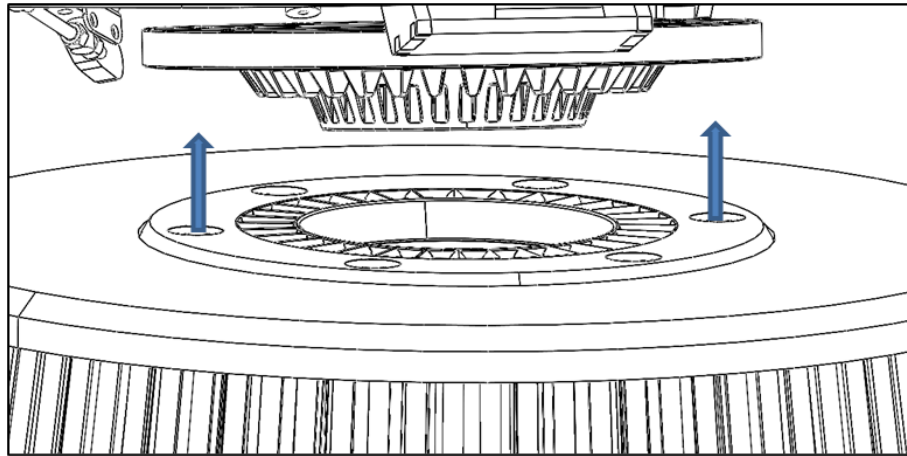

Fig. 3

5. Pull the rubber guard down back into its original position and repeat the same steps for the other brush.

CLEANING THE BRUSHES

Keeping the brushes clean enables better cleaning of the floor and a longer lifespan of the brush gearmotors. Brushes are advised to be replaced every month or as needed to get better cleaning performance. To detach the brushes for cleaning, follow these steps:

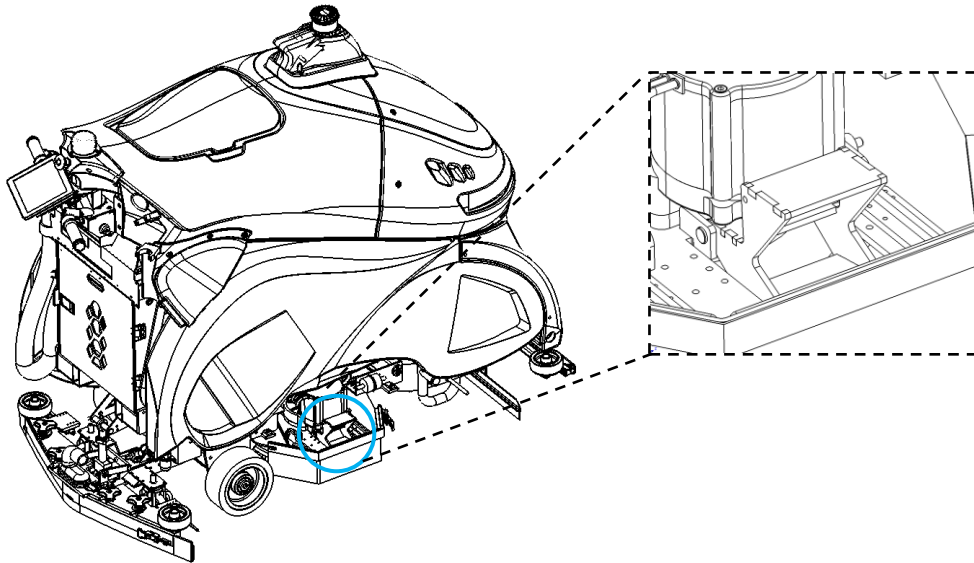

Fig. 1

1. Step on the pedal to release the brush from the magnetic clutches (Fig. 1).
2. Pull out the two brushes and clean under a stream of running water to remove impurities from the bristles.
3. Check the wear status of the bristles and replace the pads if necessary. Refer to the section [‘REPLACING THE PADS’](#) to replace worn out pads.
4. Upon checking and cleaning the brushes, re-assemble them onto their clutches as described in the section [‘MOUNTING THE BRUSHES’](#).

MOUNTING THE RUBBER GUARDS

1. Install rubber blade by opening the latch (Fig 1 highlight).

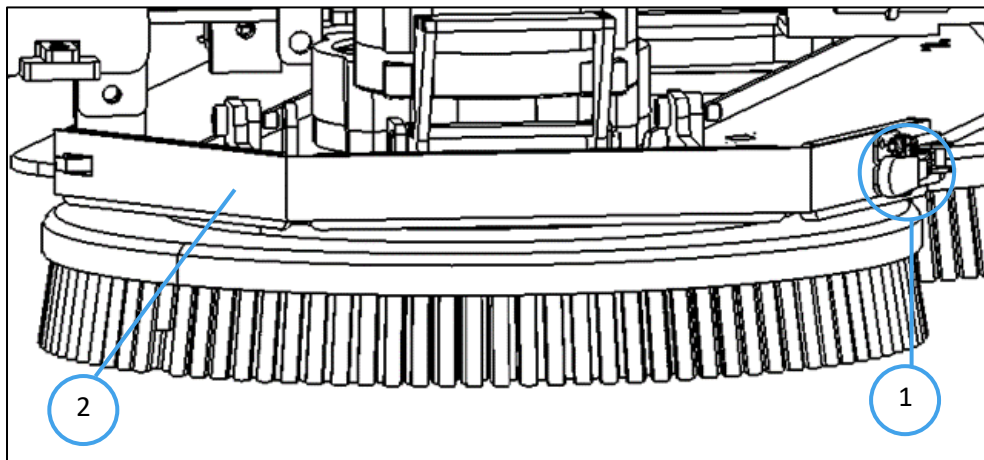

Fig. 1

2. Unhook the metal blade (Fig 1 - 2).
3. Align the brush rubber guard slots to the blocks.

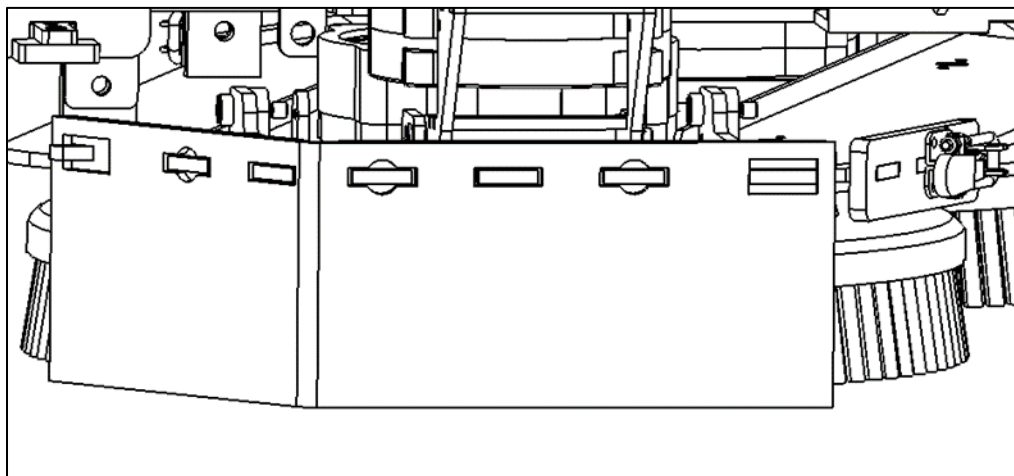

Fig. 2

4. Hook the clamp and realign the rubber guard to fit.
5. Close the latch to hold rubber guard in place.
6. Repeat steps 1 to 5 for the other side.

CLEANING THE RUBBER GUARDS

1. Unlock the latch attached to the front end of the metal blade (Fig. 1-1).
2. Remove the metal blade.
3. Peel off the rubber guards and clean it with a jet of water or damp cloth.
4. Check the wear status of the rubber and replace if necessary.
5. Refer to the section [‘MOUNTING THE RUBBER GUARDS’](#) to re-attach the rubber guards.

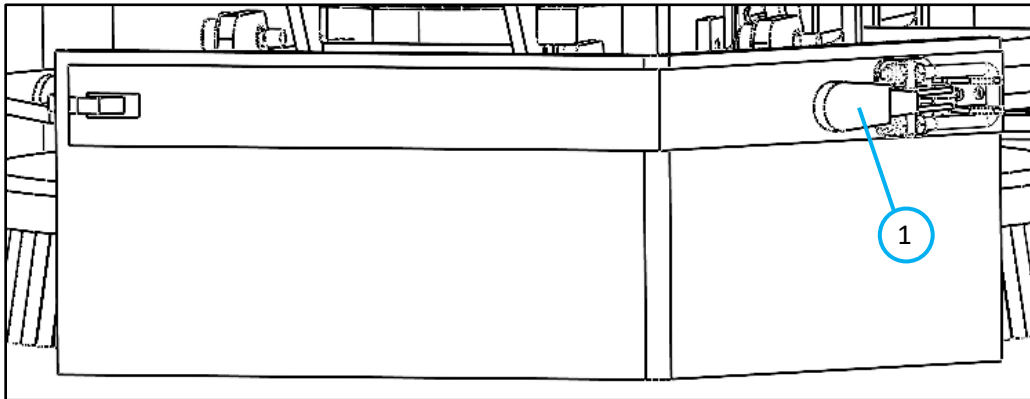

Fig. 1

SQUEEGEE ASSEMBLY

Installation of the Front Squeegee Blade

1. Place the Squeegee mount on level ground.
2. Unscrew the knobs (anti-clockwise) holding down the squeegee cartridge (Fig.1) and push the metal blocks up to detach it from the squeegee mount. Carefully store the squeegee cartridge knobs.

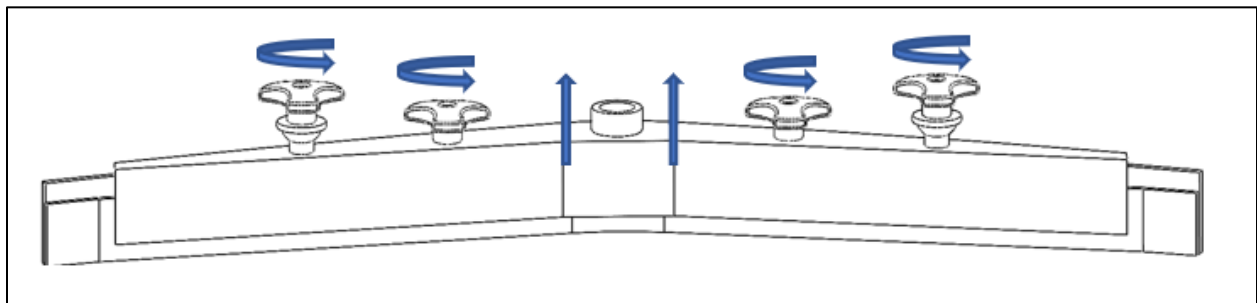

Fig. 1

3. Push the metal guard located at the middle of the squeegee assembly upwards in the direction of the knobs.
4. Attach new front rubber blades, aligning the slots with the protrusions provided on the squeegee cartridge (Fig. 3).

5. Push the metal guard down and partially tighten (clockwise) all knobs attaching front rubber blade to the squeegee assembly.

Installation of Back Squeegee Blade

6. Open the latch on the Squeegee assembly (Fig 2) and remove the metal blade.

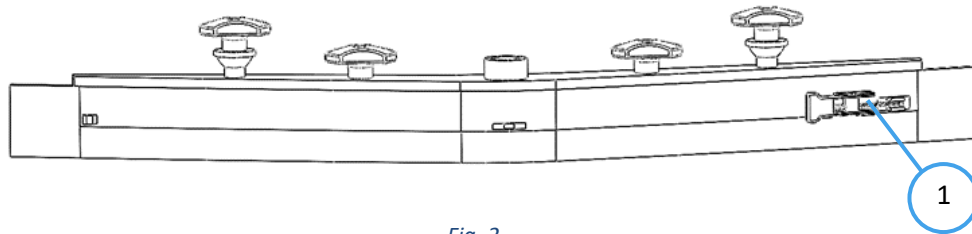

Fig. 2

7. Attach the new blade to the squeegee mount, aligning the hook (Fig. 3 – 1) and rubber slot to the blocks (Fig. 3 - 2).

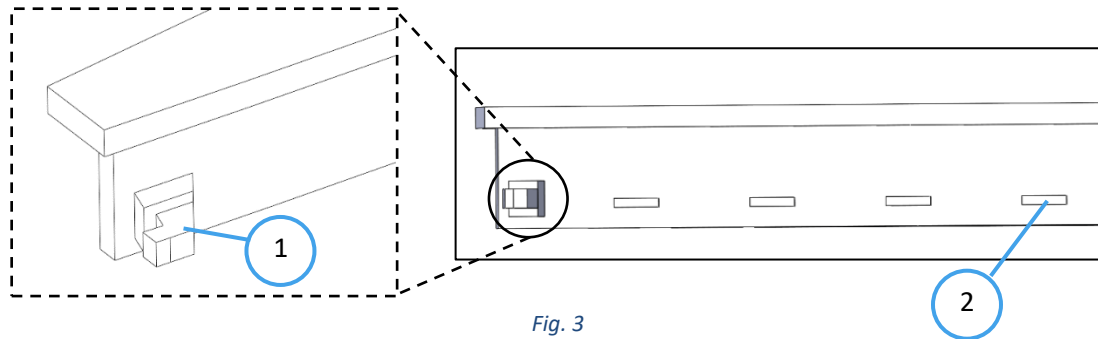

Fig. 3

8. Check alignment of the rubber blade.
9. Re-attach the metal blade and close the latch.

MOUNTING THE SQUEEGEE ASSEMBLY

1. Loosen the 4 blue knobs on the squeegee assemble shown (Fig. 1).

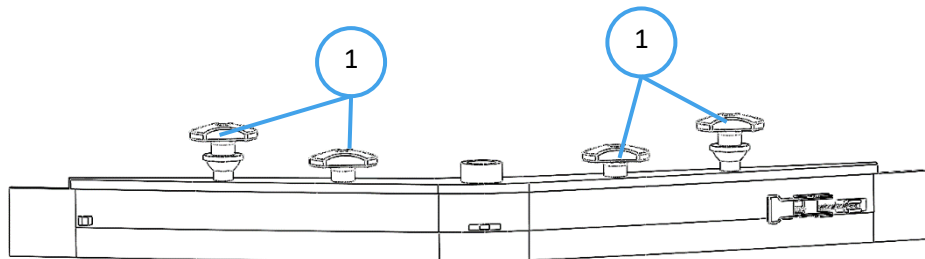

Fig. 1

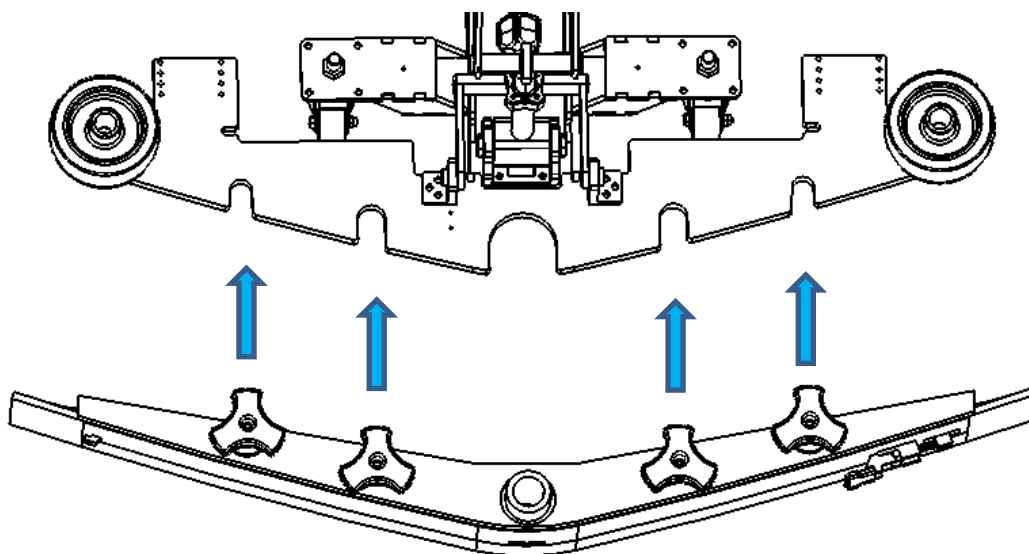

Fig. 2

2. Slide the squeegee assembly onto the mounting plate (Fig. 2).
3. Tighten all four knobs from outside to inside of the assembly.
4. To verify that the squeegee is installed correctly, pull on it, to check that the hose does not come out, gently pull on it.

CLEANING THE SQUEEGEE

Keeping the squeegee clean enables better drying of the floor and a longer lifespan of the vacuum motor. To separate the squeegee assembly from the robot for cleaning, follow these steps:

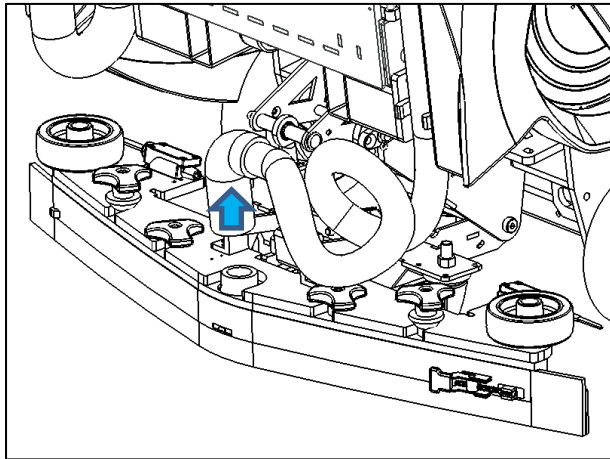

Fig. 1

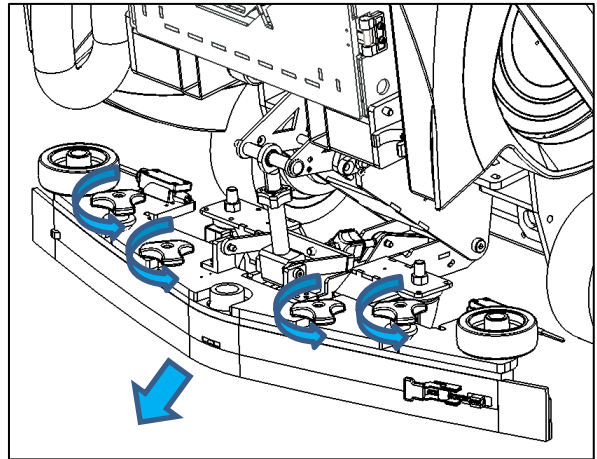

Fig. 2

1. Start by removing hose from the squeegee assembly (Fig 1).
2. Loosen the knobs and pull the squeegee assembly out (Fig 2).
3. To remove the squeegee assembly from the robot, loosen the two outer mounting knobs, pull the Squeegee assembly out and place it on level ground (Fig. 2).

Removing the back rubber

1. To remove the rear squeegee blade, unlock the latch and remove the metal blade (Fig. 3 – 1).
2. Peel off the rear rubber blade from the squeegee cartridge.

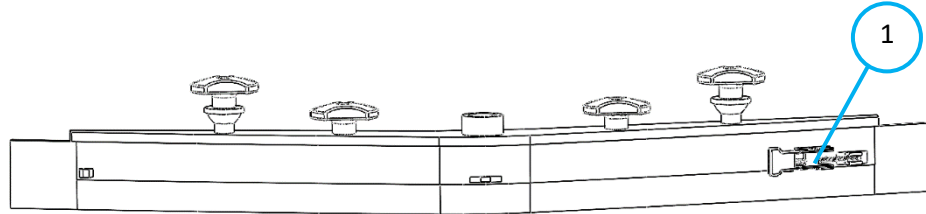

Fig. 3

Removing the front rubber

3. To remove the front squeegee blade, fully loosen inner knobs on the assembly (Fig 4).

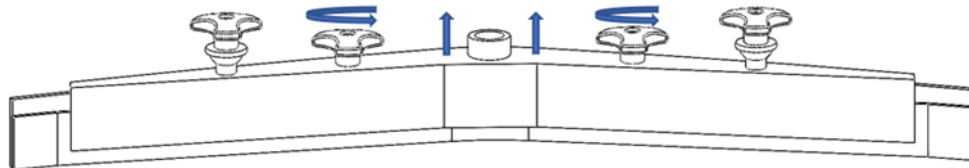

Fig. 4

4. Push up the metal guard towards the knobs and peel off the front rubber blade from the squeegee cartridge.
5. Clean the rubber blades under a stream of running water or with a damp cloth to remove impurities, such as hair, dirt, sand etc.
6. Inspect the rubber blades for wear and tear and replace as necessary before reassembling.
7. Refer to section [‘INSTALLING SQUEEGEE RUBBER ONTO SQUEEGEE MOUNT’](#) to reattach the rubber blades back onto the squeegee cartridge.



Note: Front and back squeegee blades are not the same. Ensure they are not swapped when re-assembling.

8. Re-assemble the squeegee assembly with the squeegee trap and mount it back onto the robot as described in [‘MOUNTING THE SQUEEGEE ASSEMBLY’](#).

REXSCRUB TOUCHSCREEN SETUP

The following section describes the setup procedure by using the LCD screen on the REX. The LCD screen uses the LionsClean app.

The LionsClean app is used to communicate to and work with the REXSCRUB. Each certified REXSCRUB user is assigned a unique user id and password for use with the app. The user must be logged-in to be able to interface with a REXSCRUB.

This section provides an overview of the main functions provided by the touch screen user interface, accessible through the Home page, Home Menu and just clean, and manual page of the app. More details on using the REXSCRUB with the available app commands can be found in [‘OPERATION OF THE REXSCRUB’](#)



Home page



Home Menu



User Profile



Inbox

INITIAL SETUP

The following section describes the setup procedure by using the LCD screen on the REX.

1. Turn on the REX, Turn on the Key Switch then press the Reset button.
2. Note the 'GETTING READY' screen on the LCD (Fig. 1).
3. Scroll down and select your language (Fig. 2).
4. Read and agree to the Terms of Use and Privacy Policy (Fig. 3).
5. Select the Wi-Fi network (Fig. 4).

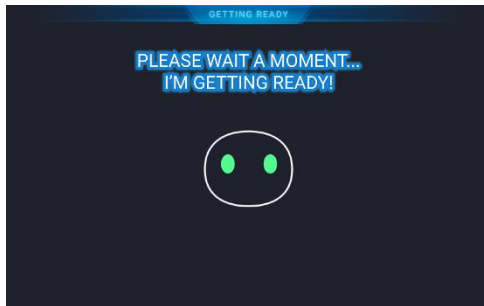

Fig. 1



Fig. 2

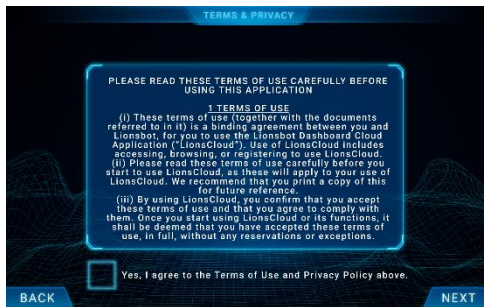

Fig. 3



Fig. 4

6. Enter the WIFI password (Fig. 5) and press connect. Wait for the 'CONNECTION SUCCESSFUL' notification (Fig. 6).
7. Should the 'FAILED TO CONNECT' screen show (Fig. 7), check the WIFI settings and password and try again. Contact the local tech support to troubleshoot the problem.

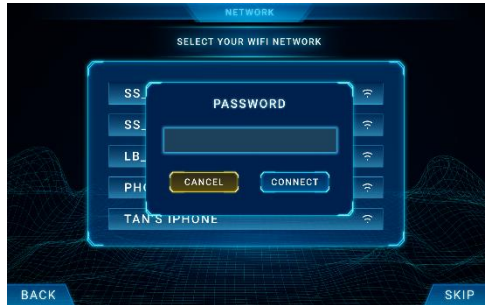

Fig. 5



Fig. 6



Fig. 7

8. Enter your name (Fig. 8).
9. Enter your pin number, remember the pin number (Fig. 9).
10. Enter your pin number again (Fig. 10).

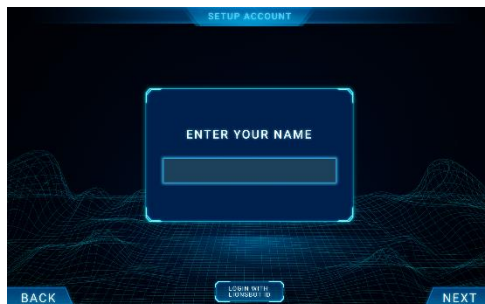

Fig. 8

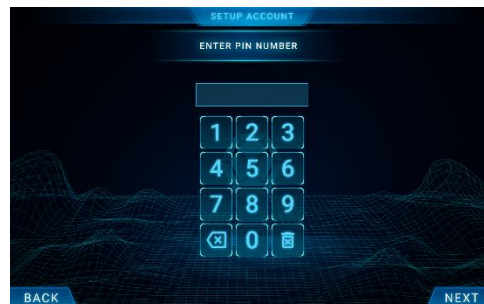

Fig. 9

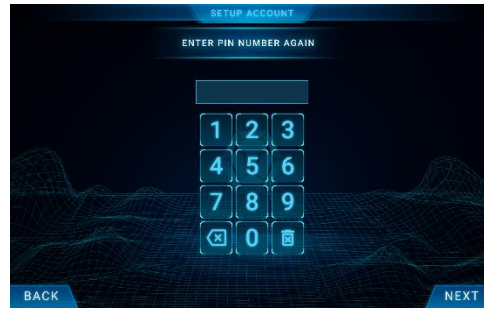

Fig. 10

11. Wait for your account to be setup (Fig. 11).

12. View the 'HOME' page (Fig. 12).

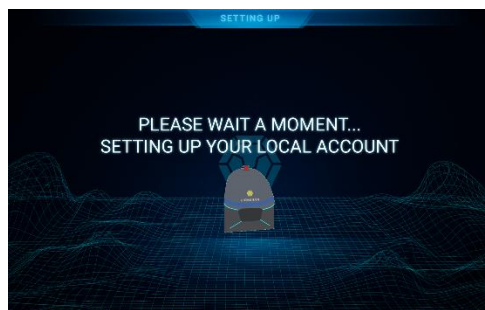

Fig. 11



Fig. 12

LOGIN WITH LOCAL ACCOUNT

The following section describes the local account procedure by using the LCD screen on the REX.

1. Select the local account for login (Fig. 1).
2. Enter your user name and pin. (Fig. 2)
3. View the 'HOME' page.



Fig. 1



Fig. 2

LOGIN WITH LIONSBOT ID (OPTIONAL)

The following section describes the Lionsbot ID login procedure by using the LCD screen on the REX.

1. Tap on the 'LOGIN WITH LIONSBOT ID' button (Fig. 1).
2. Key in your User name and password (Fig. 2).
3. View the 'HOME' page.



Fig 1



Fig 2

USER ACCOUNT MANAGEMENT

This section provides instructions for adding/ removing users.

1. From the User menu select 'MANAGE USERS'.
2. On the 'USERS MANAGEMENT' screen select 'NEW USER'.
3. Enter the user's name and role.
4. Confirm user details.



Fig 1



Fig 2

5. Assign a 6-digit pin to the user.
6. Re Enter 6-digit pin.
7. The user account setup is complete.



Fig 3



Fig 4



Fig 5



Fig 6

TEACH ROBOT

The “TEACH ROBOT” function is used to add a new cleaning location. The function maps the operating environment, with user assistance zone cleaning areas and set the home point for the robot.

1. From the home page, select ‘TEACH ROBOT’.
2. To manually teach the robot select the ‘BRING ROBOT AROUND’.
3. For automated teaching select ‘AUTO’.
4. Wait for the ‘ROBOT GETTING READY’ screen.
5. If the ‘ROBOT NOT READY’ screen (Fig 3) is shown click continue and try again (Fig 1).
6. Once mapping is complete, enter the name of the map, building and level.
7. Click on save.

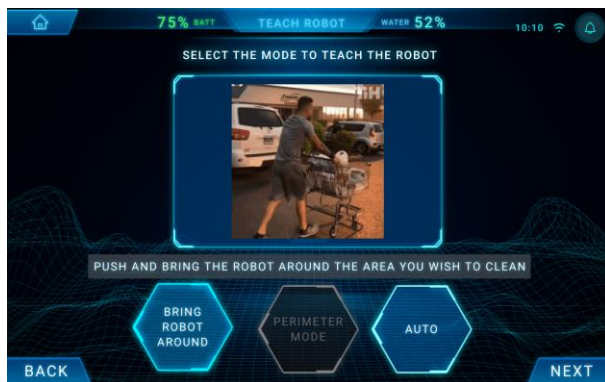

Fig 1

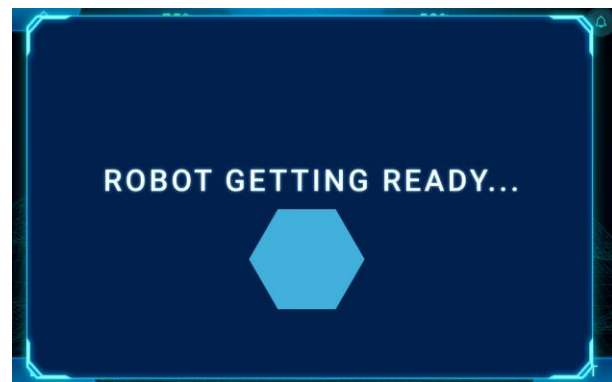

Fig 2

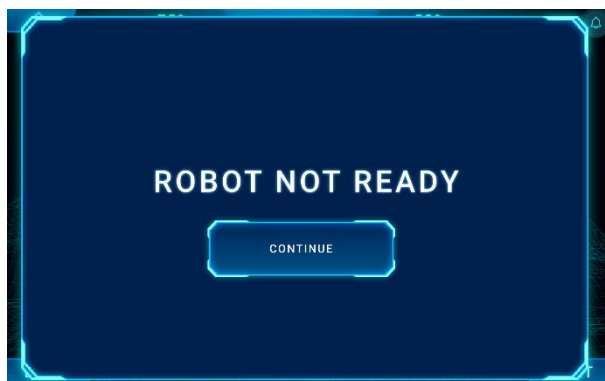

Fig 3



Fig 4



Fig 5

8. Define the 'CLEANING ZONE' in the 'EDIT MAP' page (Fig 6).
9. Define the 'RESTRICTED ZONE', e.g., such as stairs and escalators.
10. Identify 'LANDMARKS' in the mapped environment.
11. Alternatively, click on 'AUTO ZONING' to zone the map.

Note: does not cover restricted zones.

12. The REX is ready to clean (Fig 7).

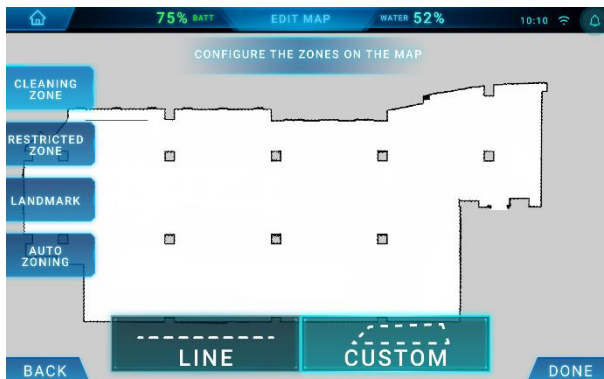

Fig 6

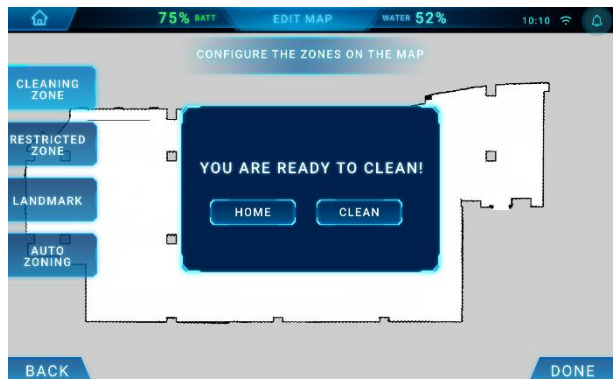

Fig 7

13. The robot will check its surroundings (Fig 9).
14. If robot is lost, bring it to the 'HOME POINT' (Fig 10).
15. Click on 'TRY AGAIN' once robot is at the HOME POINT.



Fig 8

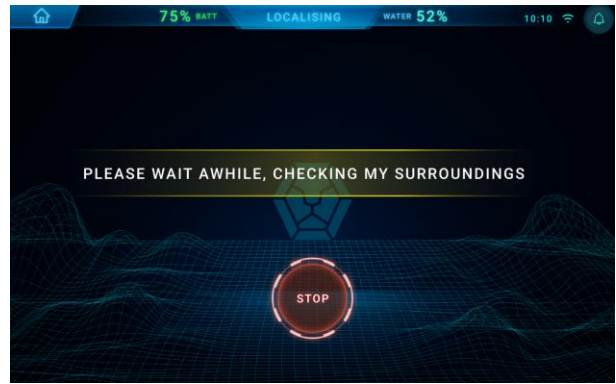

Fig 9

16. Select the map location (Fig 11).
17. Select the cleaning zone.

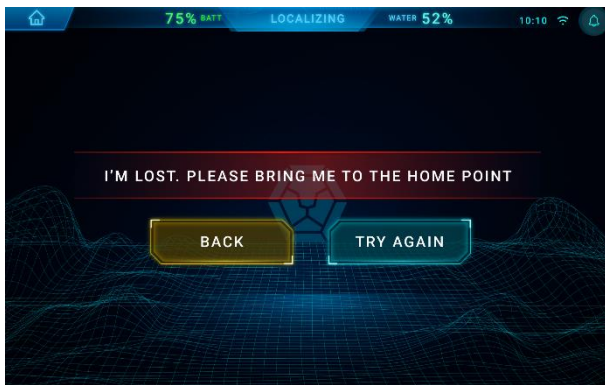

Fig 10

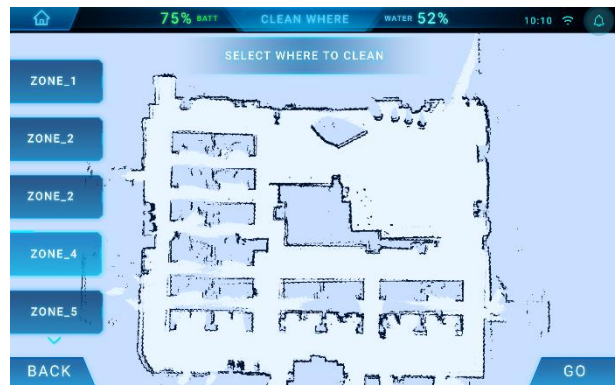

Fig 11

18. The robot LCD screen will update the cleaning progress.
19. The user may pause or stop the cleaning process at any time.



Fig 12

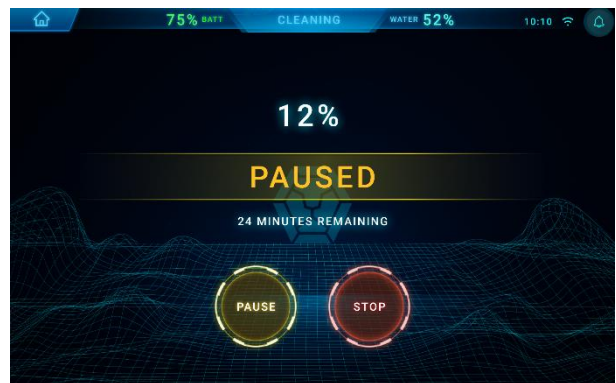

Fig 13

20. Once cleaning is complete the REX will generate a cleaning report.



Fig 14



Fig 15

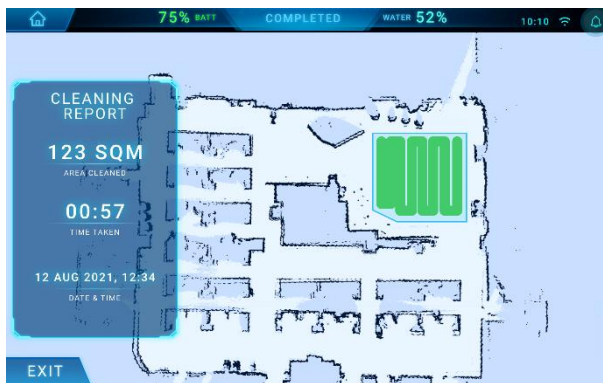

Fig 16

CHANGE MAP

The following section instructs the user on how to change the mapped environment in which REX is operating.

1. On the 'Home Page', select 'MAPS'.
2. Select the map to change, wait for the map change to be successful.
3. If map loading has failed, try again. Should map change fail, contact Lionsbot.
4. Select the start point of the robot.



Fig 1



Fig 2



Fig 3



Fig 4

5. Wait for the robot to check its surroundings.
6. If robot fails to localize, tray again or press back and reselect start point.
7. The robot has localized (Fig 1).

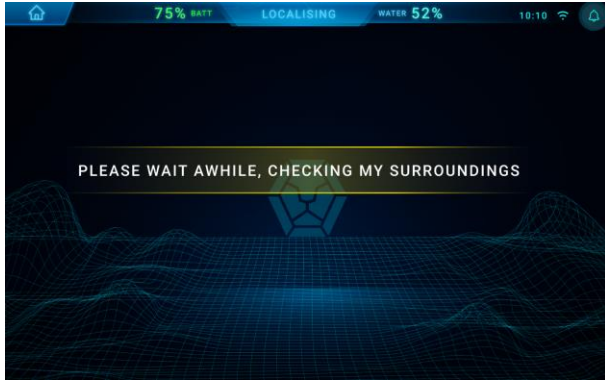

Fig 5

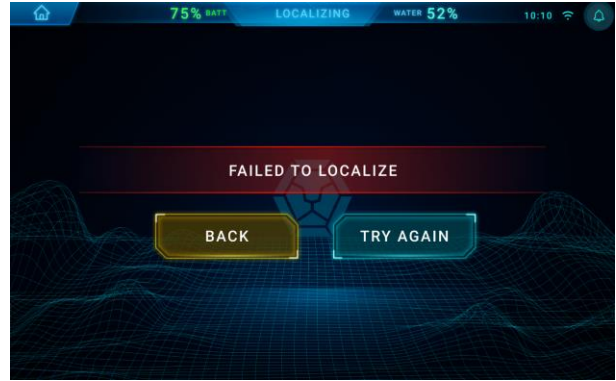

Fig 6

To Update the MAP refer to the '[UPDATING THE MAPS SECTION](#)'.

JUST CLEAN

There are 3 modes of selection of cleaning in this mode:

Option 1: Square Mode

1. Select the area size to clean by scrolling on the screen.
2. Press 'START'.



Fig 1

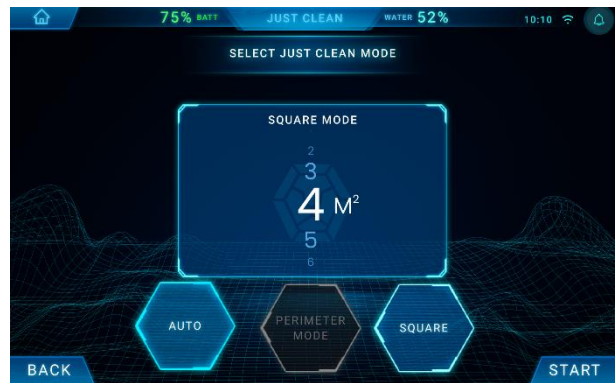

Fig 2



Fig 3

3. A 'CLEANING IN PROGRESS' screen will show.
4. Once cleaning is complete a report is generated.

Option 2: Perimeter Mode

1. Select perimeter mode (Fig 4).
2. Manually Pilot the robot along the perimeter (Fig 5).
3. Press 'CLEAN'.

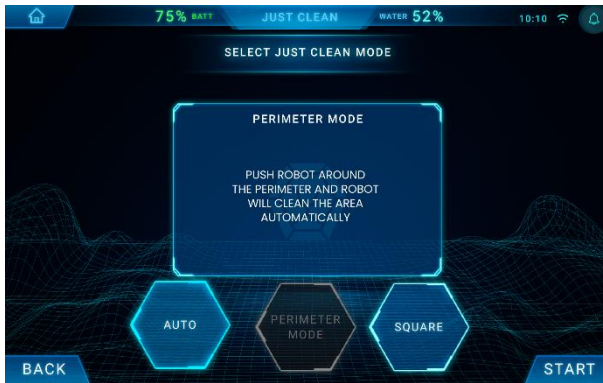

Fig 4



Fig 5

Option 3: Auto Mode

1. Press 'START'.



Fig 6



Fig 7

CLEANING REPORT

A cleaning report is generated once cleaning is complete.

Go to the [REPORTS](#) section for more information.



Fig 8

MANUAL CLEAN

The following section instructs the user on how manual clean on the REX.

1. On the Home screen select the 'MANUAL CLEAN' button.
2. Select cleaning presets: "MAX", "ECO", "DRY", "CUSTOM 1", "CUSTOM 2", "SETTINGS".
3. For custom 1 and 2 The sliders (Fig 2) controls robot water level, solution ratio, brush pressure, brush speed, vacuum suction and squeegee pressure. Select your custom settings and select save.
4. After selecting your settings select the 'START' button to start cleaning (Fig 1).
5. Start cleaning.

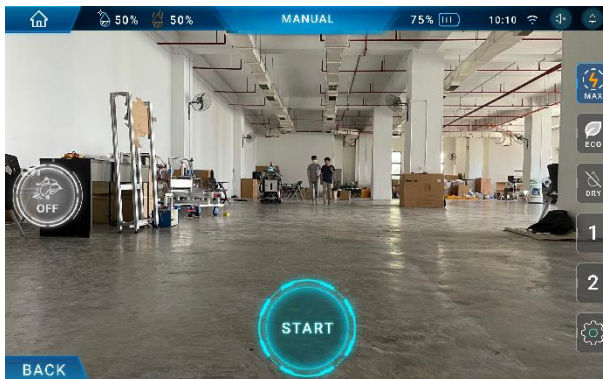

Fig 1

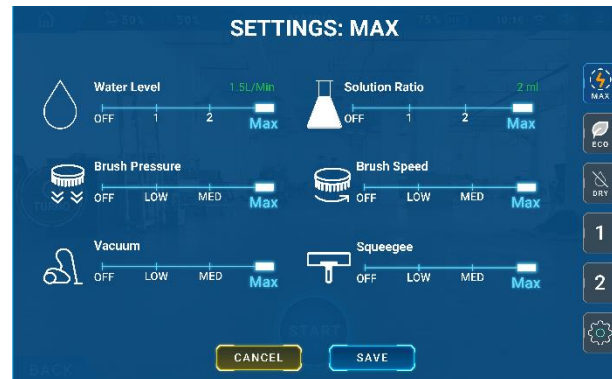

Fig 2

For a faster movement speed select the 'TURBO' button (Fig 3).

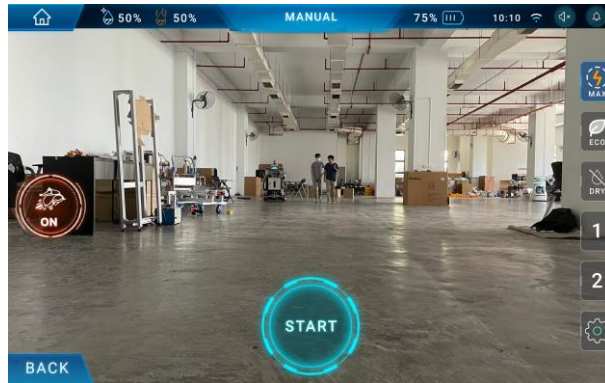

Fig 3



WARNING: Turbo function should only be turned on by a user who is familiar and comfortable with operating the REX SCRUB manually.

SETTINGS

This section instructs the user on changing settings on the LCD screen. The Setting page allows the user to change general settings, language, network, User interface themes.

1. On the general settings page the user can adjust screen brightness, sound volume and screen timeout settings (Fig 1).
2. The user may change the language by clicking the language tab and scroll through the language window (Fig 2).

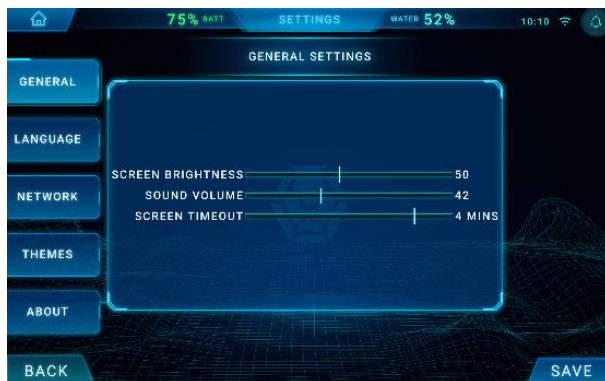

Fig 1



Fig 2

3. The user may change the operating network by selecting the network under the network tab (Fig 3).
4. Enter the network password (Fig 4).
5. If the connection is successful (Fig 5), network change is successful.
6. Should the screen show fail to connect (Fig 6), check your network configuration and settings and try again. Otherwise contact your network administrator.

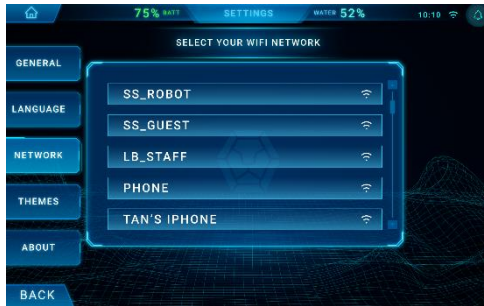

Fig 3



Fig 4



Fig 5



Fig 6

7. The user may select the LCD theme (Fig 7).
8. About Lionsbot (Fig 8).



Fig 7



Fig 8

REPORTS

The following section instructs the user on how to access reports:

1. From the home page click on the user menu.
2. Select the reports icon.

Reports can be viewed on a monthly basis. A daily report basic cleaning data shown is time, mapped area, cleaning area covered and obstacles detected.



Fig 1



Fig 2

BEFORE REXSCRUB USE

Power on the robot as described in the section “[POWERING ON/OFF THE REX SCRUB](#)” to be able to move and operate it.

Follow this checklist of operations before beginning to clean with the REXSCRUB:

- I. **Clean Water** level is sufficient. (refer to ‘FILLING THE CLEAN WATER TANK’)
- II. Chemical is replenished.
- III. Battery charge level is sufficient. (refer to ‘CHARGING THE BATTERY’)
- IV. No fluid leaks.
- V. Safety features and devices are operating.
- VI. Brakes and steering for proper operation.
- VII. REXSCRUB is localized.
- VIII. REXSCRUB can be moved to desired location.
- IX. E-Stop button is released before cleaning.
- X. Brushes/Pads are mounted securely (dependent on floor type)
- XI. Squeegee is clean of dirt
- XII. Debris cage is empty (See Fig 1)
- XIII. Recovery tank is empty

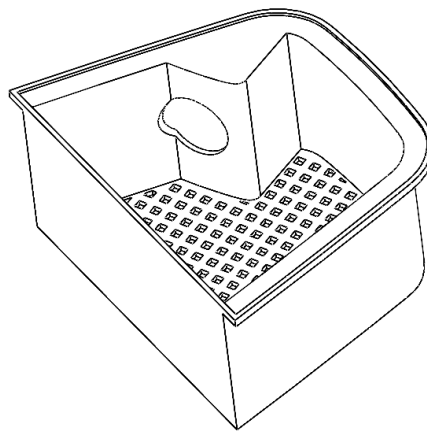

Fig 1

TRANSPORTING THE REXSCRUB OUT OF STORAGE

Follow the stipulated safety requirements (see ‘[TRANSPORT](#)’) to transport the REXSCRUB out of storage to the working area.

CHECKING THE WATER LEVEL

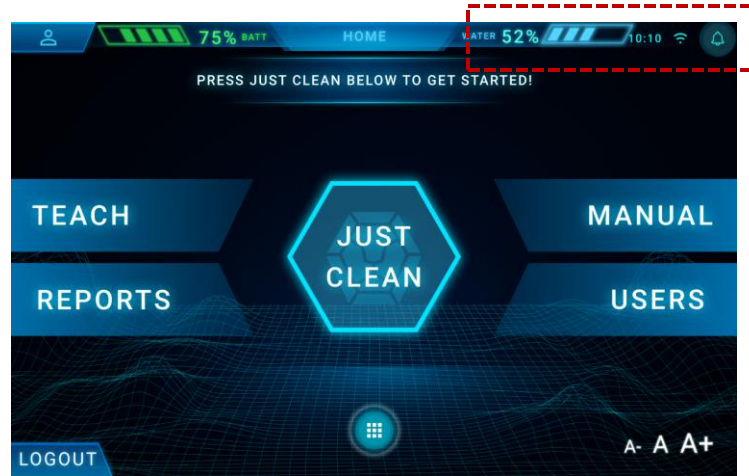

Fig. 1

1. Check the clean water level (Fig. 1 -RED BOX) on the touch screen attached to the REXSCRUB.
2. Empty the recovery tank of any waste water before usage (see ['EMPTYING THE RECOVERY TANK'](#)).

FILLING THE CLEAN WATER TANK

If water level is insufficient, bring the robot near a water source. The robot may be either on or off for this process.

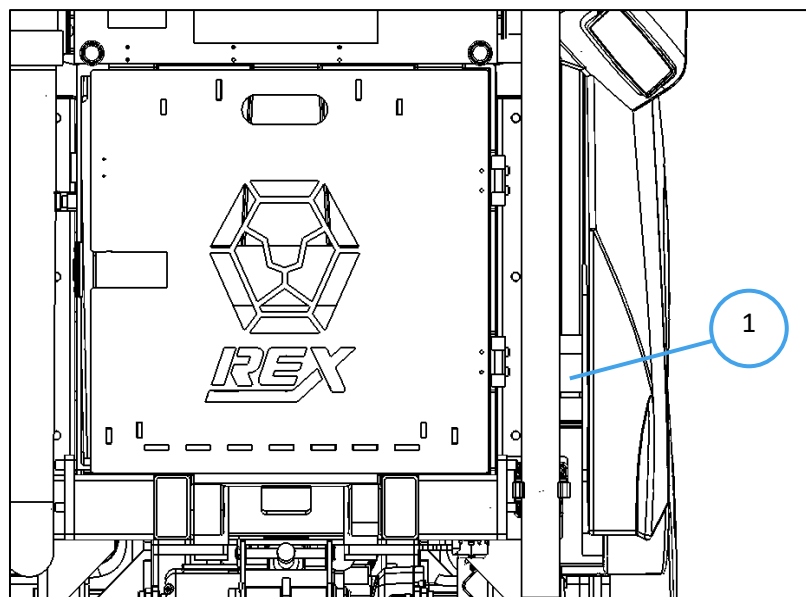

Fig. 1

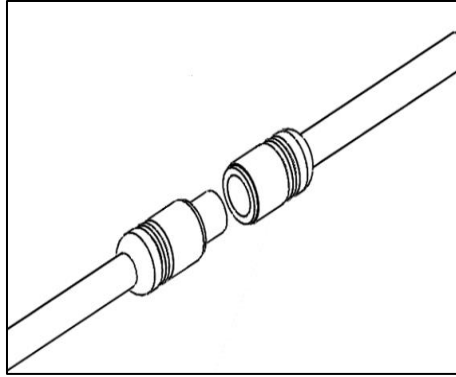

Fig. 2

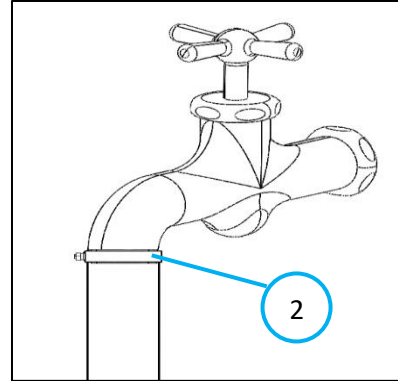

Fig. 3

Follow these steps to refill the clean water tank:

1. Prepare a hose for clean water.
2. Attach the hose inlet to a tap by pushing its rubber end onto the tap and tightening the hose clip (Fig. 3).
3. Access the REXSCRUB clean water tank inlet beside the vacuum hose (Fig. 1 - 1).
4. Insert the plug side of the tap hose into the quick-connect terminal of clean water tank hose (Fig. 2). A 'click' sound indicates correct attachment.
5. Hold the hose in place and turn on the tap.
6. Once filled to a sufficient level indicated on the water level meter on the touch screen, turn OFF the tap.
7. Remove the hose from the inlet and turn the knob to the 'OFF' position.



CAUTION: Do not attempt to fill the robot past the 100% mark – water will immediately overflow next to the squeegee (Fig 4).

CHECKING THE BATTERY LEVEL

1. Refer to the Home page on the screen for the robot to check the battery level (Fig. 1)

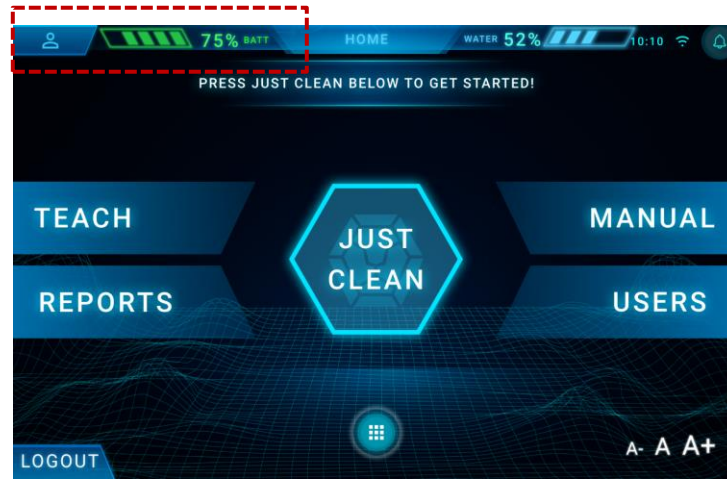

Fig. 1

LOCALIZING THE ROBOT



CAUTION: Localization errors or navigation errors will happen under the following conditions:

1. Lidars' surfaces are dirty
2. Sudden loss of power to on-board computer.

The REXSCRUB needs human assistance to ensure proper localization. If robot is not localized the LEDs will turn purple.

1. Access the map of the facility by clicking the 'Map' option on the HOME (EXPAND MENU) page (Fig. 1).



Fig. 1



Fig. 2

2. Select the mapped area of operation (Fig 2), wait for the map to change.



Fig. 3

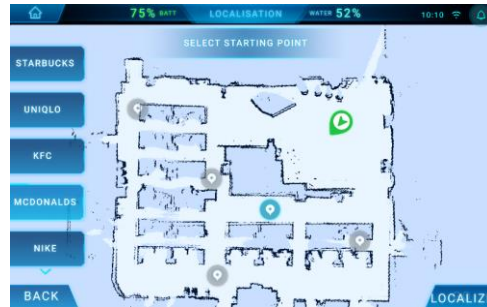

Fig. 4

3. Click on the level-selector drop-down button on the map page (Fig. 2) to select and activate the robot is currently on (Fig. 3).
4. The REXSCRUB's position on the map is indicated by an arrowhead (Fig. 4). The points and segments on the map reflect the robot's vision through the LIDAR.
5. Manually move robot to a localization point selected on the map, then select the localize button. Wait for the robot to check its surroundings (Fig 5).
6. When localization is successful the robot will show on the 'HOME point'.

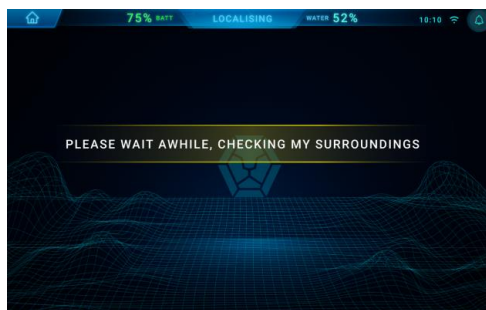

Fig. 5



Fig. 6

VERIFICATION OF LOCALIZATION

1. With a properly localized REXSCRUB, the LIDAR scan lines (indicated by points and segments on the map) would closely match map features (displayed as black lines) (as seen in Fig. 1). If the REXSCRUB's scan displayed on the app does not match the map features satisfactorily, the robot can be repositioned slightly to repeat the localization setting.

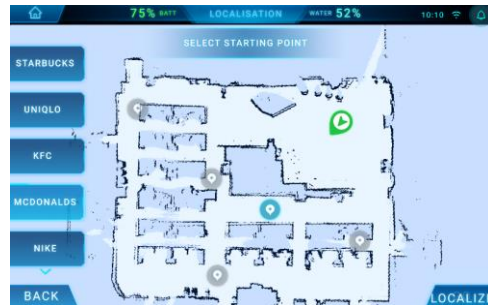

Fig. 1

2. Another indicator of good localization is successful point-to-point motion of the REXSCRUB. Use the Move command as described in '[POINT TO POINT MOVEMENT](#)' to verify accurate movement to a set location.

OPERATION OF THE REXSCRUB

The REXSCRUB can be operated through the touchscreen. Follow the procedure under '[REXSCRUB TOUCHSCREEN SETUP](#)' to get the REXSCRUB running and to perform localization.

Complete the final maintenance checklist below before beginning to work with the REXSCRUB. This maintenance checklist will also appear as a reminder on the touchscreen.



WARNING: If either the E-stop or bumper are not found to be working as expected, do not proceed to clean with the REXSCRUB and contact an authorized distributor for assistance.

- ✓ Verify the physical E-stop and reset button are functioning and LED warning light.
- ✓ Verify the Safety bumper function.
- ✓ Verify that the obstacle avoidance behavior is functioning.
- ✓ Check lidar surfaces for any dirt.
- ✓ Verify that the recovery tank hatch is closed.
- ✓ Verify that the drain hose is lidded and secured.
- ✓ Verify that the fresh water refilling hose is completely emptied of water.
- ✓ Verify that the squeegee suction hose is tight on the squeegee and to the recovery tank.
- ✓ Verify that the brushes and pads are mounted securely (dependent on floor type)
- ✓ Verify the chemical cabinet is shut tight.

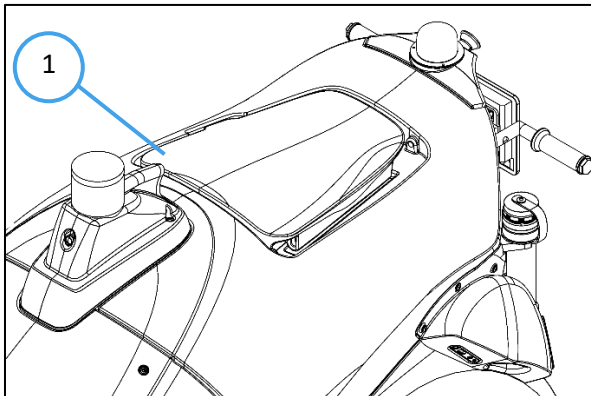

Fig. 1

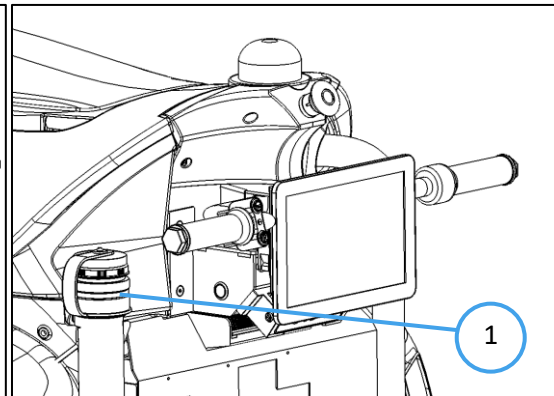

Fig. 2

1. **Verify the physical E-stop and RESET button function:** After depressing the E-stop, push the robot from the front to verify that the brakes have been engaged and check LED lights are flashing Red color.. Release the E-stop and press the reset button, to verify LED lights go back to blue color.
2. **Verify the Safety bumper function:** After manually depressing the rubber bumper, push the robot from the front to verify that the brakes have been engaged and also check LED lights are flashing Red color. Press the reset button to verify LED lights go back to original color.

3. **Verify that the obstacle avoidance behavior is functioning:** Pilot the robot with the 'Sensor On' to move the robot towards an obstacle (directly in front or on the sides) and verify that the robot avoids the obstacle (see '[OBSTACLE AVOIDANCE](#)' section).
4. **Verify LIDAR and camera surfaces is clean:** Check visually lidars surface for any dirt, dust and grease marks. Wipe lidar surface with a small cloth to remove dirt.
5. **Verify recovery tank hatch is closed** (Fig. 1 – 1).
6. **Verify drain hose is lidded and secured:** Tightly close the drain hose lid (Fig. 2 - 1) and rest the hose on the anchor points provided.

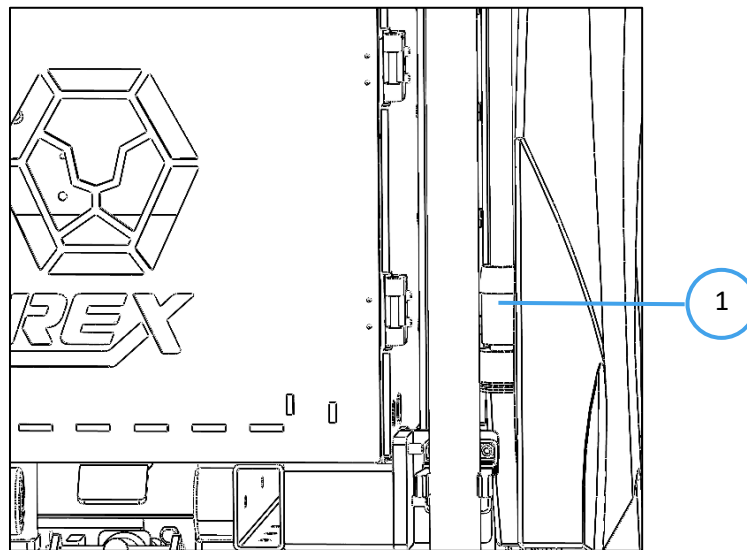

Fig. 3

7. **Verify fresh water hose is free of water.** (Fig. 3 – 1).
8. **Verify the filters and hoses are not choked.**
 - I. Squeegee hose is must not be choked.
 - II. Debris cage in the recovery tank is empty.

POINT TO POINT MOVEMENT

1. Use the 'Move' option (Fig. 1) on the Expanded Menu page to select a point on the map (Fig. 2) for the robot to move to from its current location.
2. The Move page allows the user to select a pre-set point to move to from the bottom selection ribbon (ex. 'MCDONALDS' in Fig. 2) or provide a custom location by clicking on the map.
3. Upon confirming the selection (Fig. 3), the pause/ stop button bar appears with a pull-up banner for the move mission status, which shows the mission progress as a percentage. Expanding this pull-up banner shows more details about the specific motion (start and end location).
4. Should there be obstacles or an interruption in the process a 'UNSUCCESSFUL' page shall show (Fig. 4). The operator may either select 'HOME', 'JUST CLEAN' or 'MOVE' functions to adjust the process.
5. Upon completion of the mission the app will display a completion page (Fig. 5).



Fig. 1

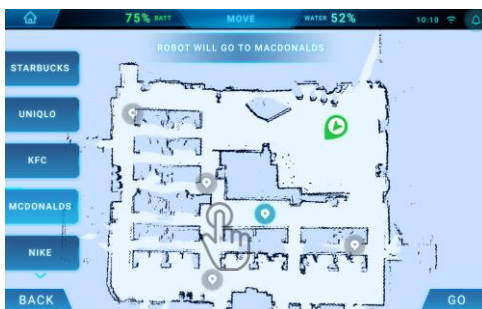

Fig. 2

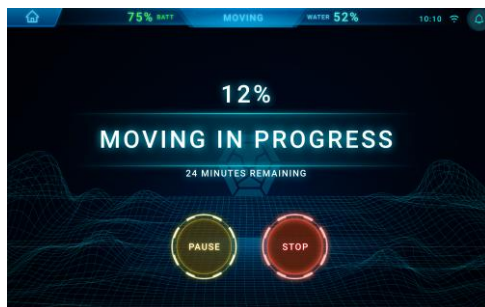

Fig. 3



Fig. 4

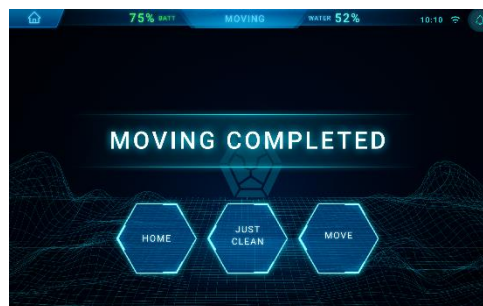



Fig. 5

AUTONOMOUS CLEANING

The operator may select the 'JUST CLEAN' button on the home page or the work tab.

For the 'JUST CLEAN' setup steps the operator may refer to the '[JUST CLEAN](#)' section of the manual.

 **Note:** Ensure the robot is localized before using this function. To select map or localize robot refer to the '[LOCALIZING THE ROBOT](#)'.

1. Click on the 'Work' option (Fig. 1) on the home page to specify a cleaning mission for the robot. The 'Work' page displays the robot position on the map, with the available cleaning zones in the surroundings highlighted in light blue (Fig. 2).
2. Optional: If robot is not localized, select Map area, then select 'CHANGE MAP' (Fig2).
3. Select 'WHERE TO CLEAN'
4. Select a cleaning zone from the map (indicated by a light blue box), or a predefined cleaning section (a group of cleaning zones) from the selection ribbon at the left of the screen (Fig. 3) and press go.
5. Select the START button in (Fig. 2).
6. Upon starting the mission, the robot will move to the start of the cleaning zone (Fig. 4). On the LionsClean app the pull-up banner can be expanded to view the mission progress, other mission specifics as well as the cleaning mode.
7. The REXSCRUB then proceeds to complete the cleaning mission, displaying the progress along the planned cleaning path.
8. A cleaning report is generated once cleaning is completed (Fig 5 – 7).



Fig. 1



Fig. 2

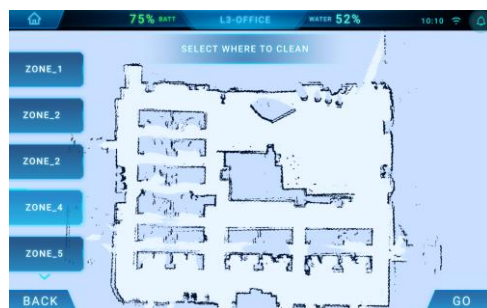

Fig. 3



Fig. 4

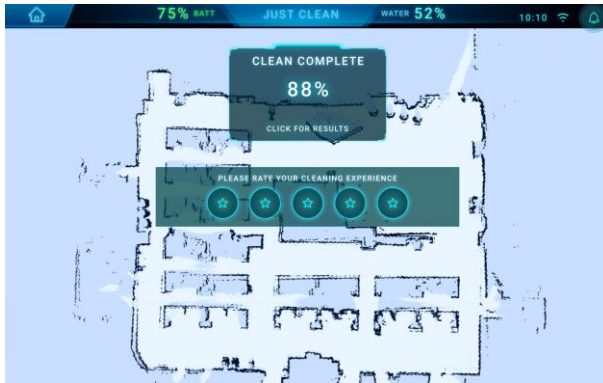

Fig. 5

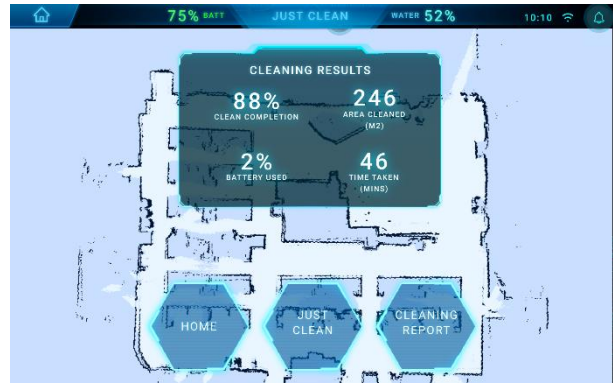

Fig. 6

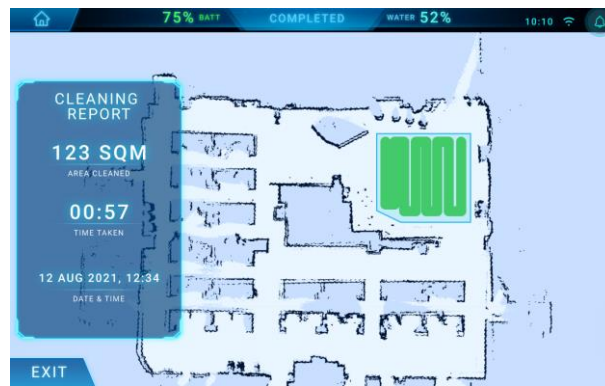

Fig. 7

Cleaning mode:

Clicking on the 'Cleaning Equalizer' (Fig. 2) brings up the advanced cleaning settings page for the scrubbing function (Fig. 8).

1. The menu features 3 pre-defined cleaning modes and two custom modes. Each cleaning mode is defined by specific settings for brush pressure, water flow rate, squeegee pressure, suction power, brush spin rate, robot speed, and cleaning path overlap.
2. The default mode – Best – is defined based on the best settings recommended by the robot distributor for the operating scenario.



Fig. 8

Each of the custom settings options can be modified using the equalizer slider and saved for future use (Fig. 8).

RECOMMENDED MAINTENANCE

Complete this checklist of operations after cleaning with the REXSCRUB:

- ✓ Stop on a level surface.
- ✓ Drain the recovery tank.
- ✓ Wash the recovery tank.
- ✓ Empty debris cage in recovery tank.
- ✓ Optional: Drain clean water tank.
- ✓ Remove and clean the squeegee.
- ✓ Move the robot back to storage.
- ✓ Charge the robot.
- ✓ Power off the robot and ensure chemical cabinet is closed.
- ✓ Wipe down the outer skin of the robot, lidar covers and cameras with a dry cloth.

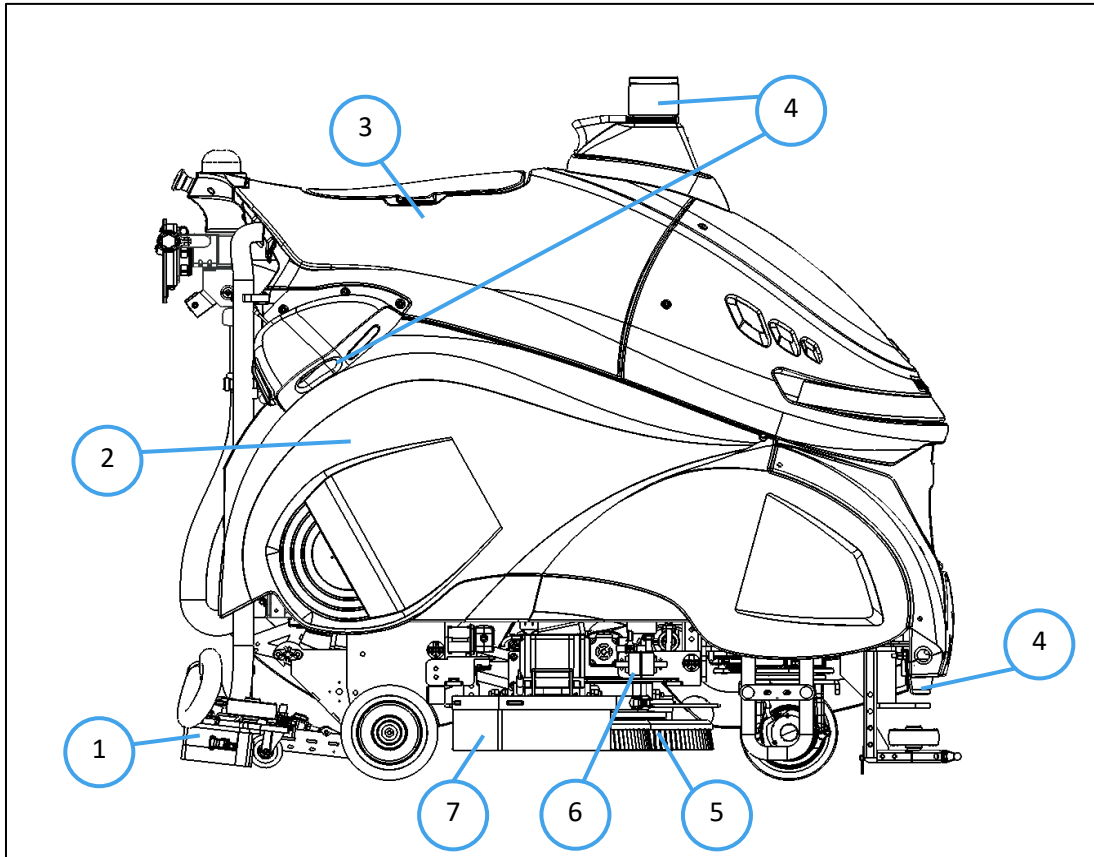

Fig. 1

- | | |
|----------------------|-------------------|
| 1. SQUEEGEE ASSEMBLY | 5. BRUSH |
| 2. CLEAN WATER TANK | 6. WATER FILTER |
| 3. RECOVERY TANK | 7. BRUSH SKIRTING |
| 4. LIDAR AND CAMERA | |

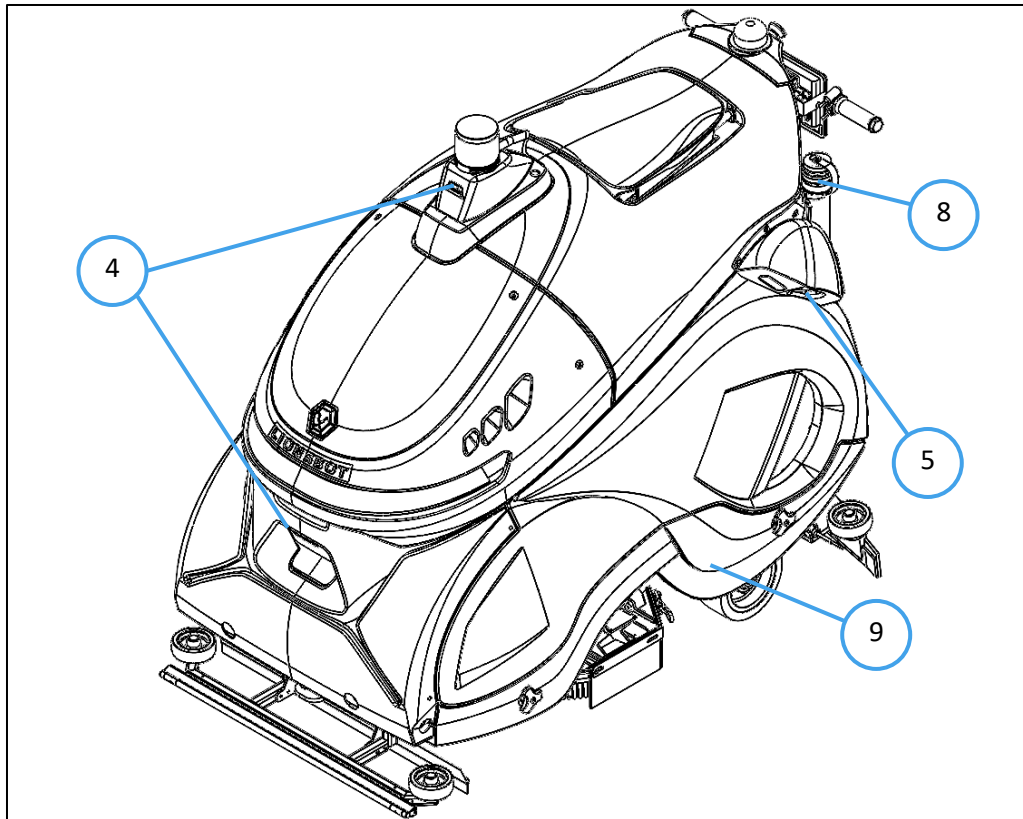

Fig. 2

- 8. RECOVERY HOSE
- 9. SIDE PANEL

DRAINING THE RECOVERY TANK

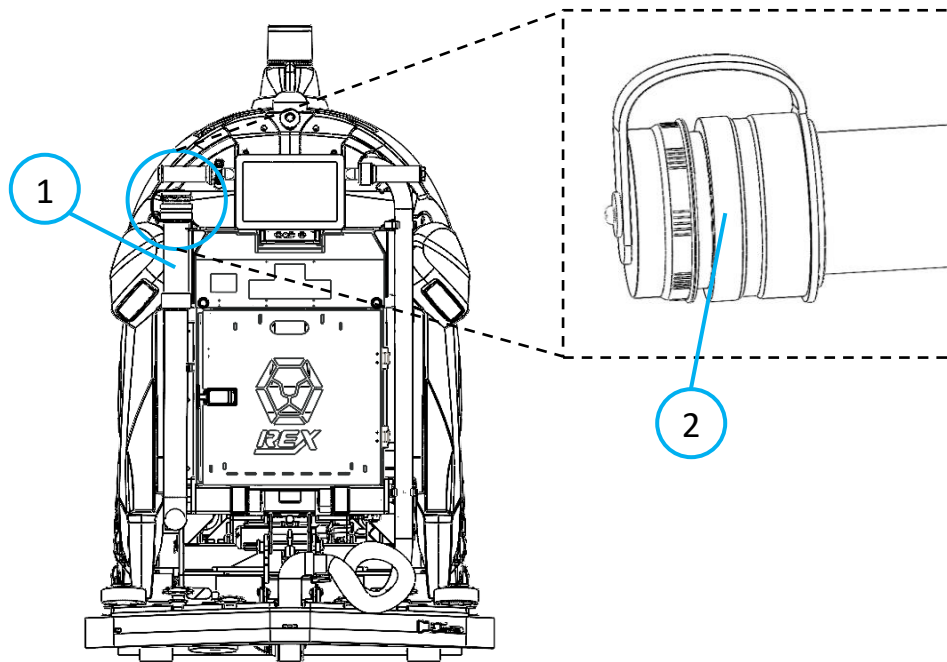

Fig. 1

1. If recovery tank has fluid, use the manual drain hose to drain fluid (Fig 1 – 1).
2. Point hose towards a drain or appointed disposal location, uncap the hose (Fig. 1 – 2).
3. Once fluid has been drained and tank is empty of fluid, refer to '[CLEANING THE RECOVERY TANK](#)' section to remove left over debris inside the tank.
4. Once cleaning is complete. Close cap on the manual drain hose.
5. Place drain hose on the holder.

CLEANING THE RECOVERY TANK



The recovery tank should be cleaned regularly to prevent the build-up of silt, grime, dirt etc. Drain the waste water tank fully (see [‘DRAINING THE RECOVERY TANK’](#)).

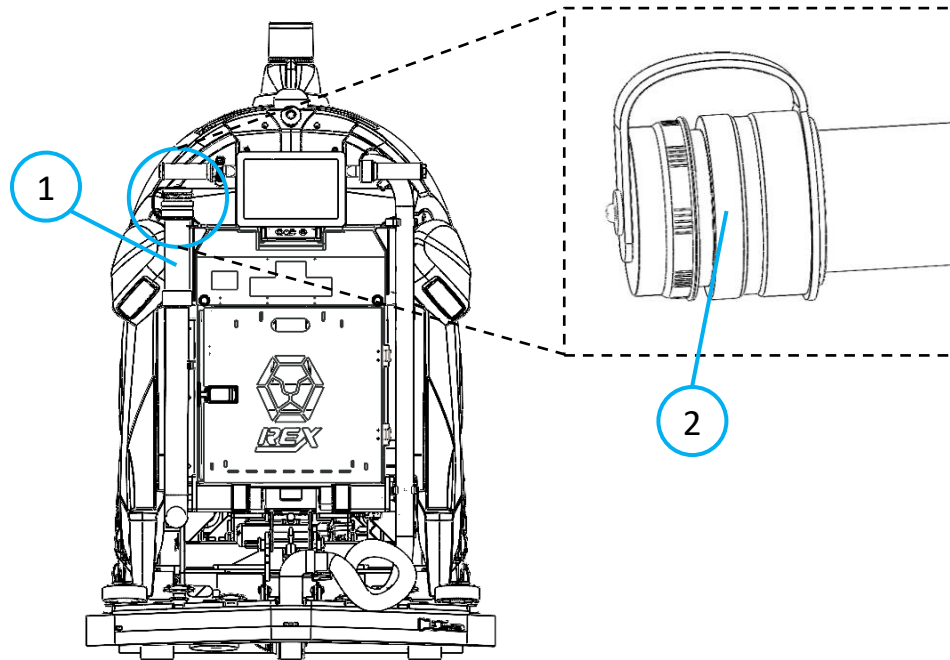

Fig. 1

1. Unmount the manual drain hose (Fig 1 – 1) from the hooks provided.
2. Point hose towards a drain or appointed disposal location and uncap the hose (Fig 1 – 2).

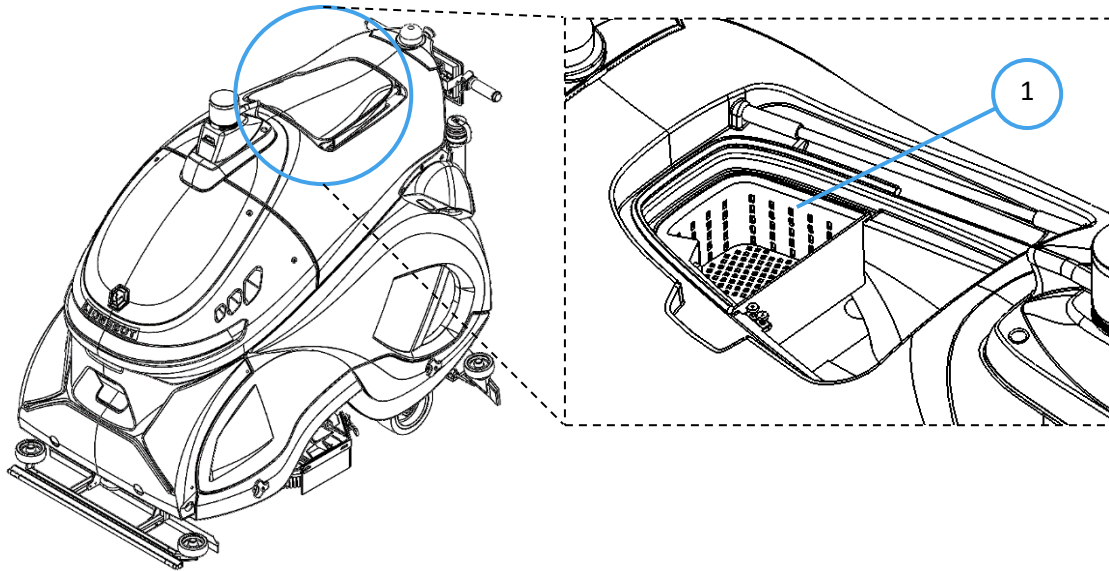

Fig. 2

3. Open the top hatch.
4. Remove the debris cage (Fig 2 – 1)
5. Empty and wash the debris cage if necessary.
6. Inspect the recovery tank for debris. Flush it with clean water and use a sponge or scrub to clean grime off the walls.
7. Check for clogging at the drain hose fitting on the inside of the tank. Clean if necessary (Fig.2).
8. Tightly cap/ shut the drain hose and mount it back onto the hooks provided.
9. Close the hatch.



Note: Do not use steam or hot water to wash tank. Heat can damage integrity of the tank.

DRAINING THE CLEAN WATER TANK

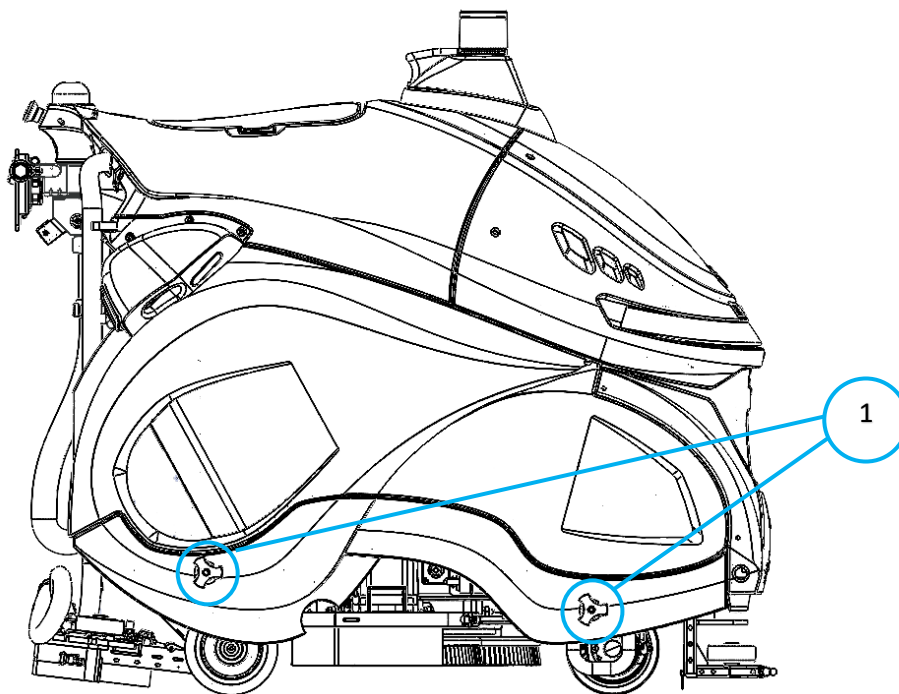

Fig. 1

1. Unfasten the two blue knobs on the right side of the REX (Fig.1).
2. Remove the side skirt panel (Fig.2).

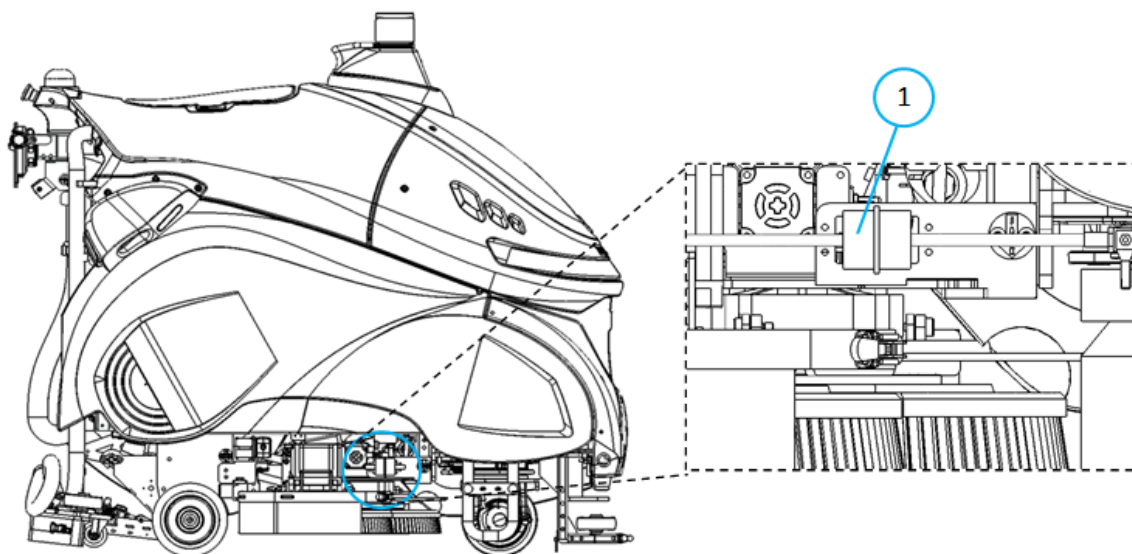

Fig. 2

3. Close the valve (Fig 2-1), then Unplug tube shown in (Fig. 3).



WARNING: Failing to close the valve will result in water spilling on the brush assembly when unplugging the tube

4. Place/ point tube towards a drain or bucket and open the valve to start draining.

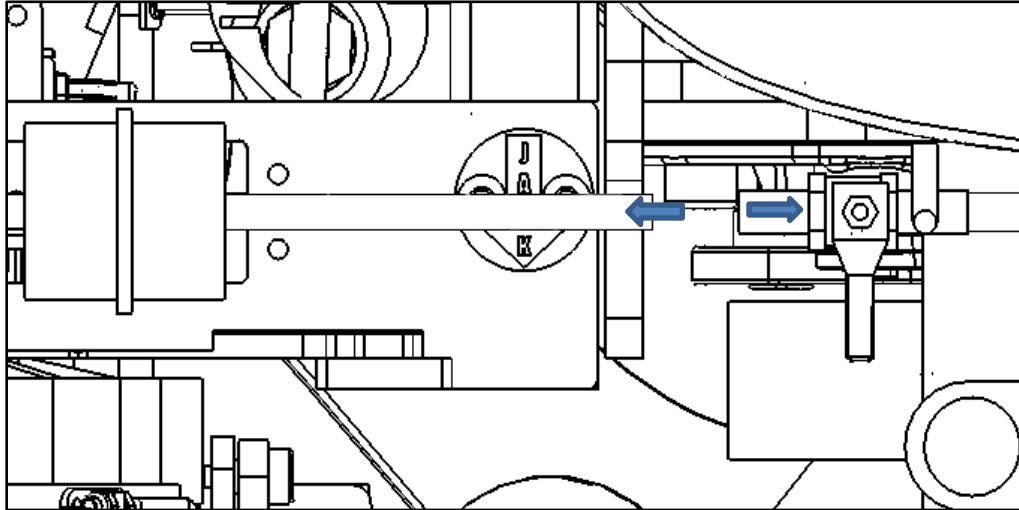

Fig. 3

5. Wait for water to drain completely before closing valve.
6. Plug the tube back into the valve.
7. Open the clean tank valve (Fig. 4).

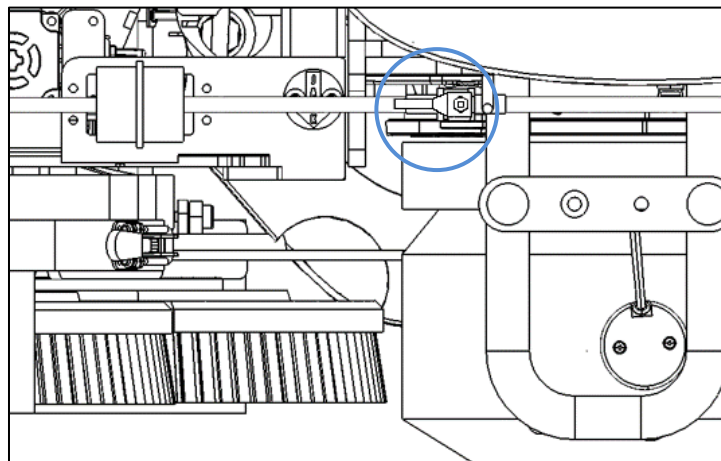

Fig. 4

CLEANING THE CLEAN WATER TANK

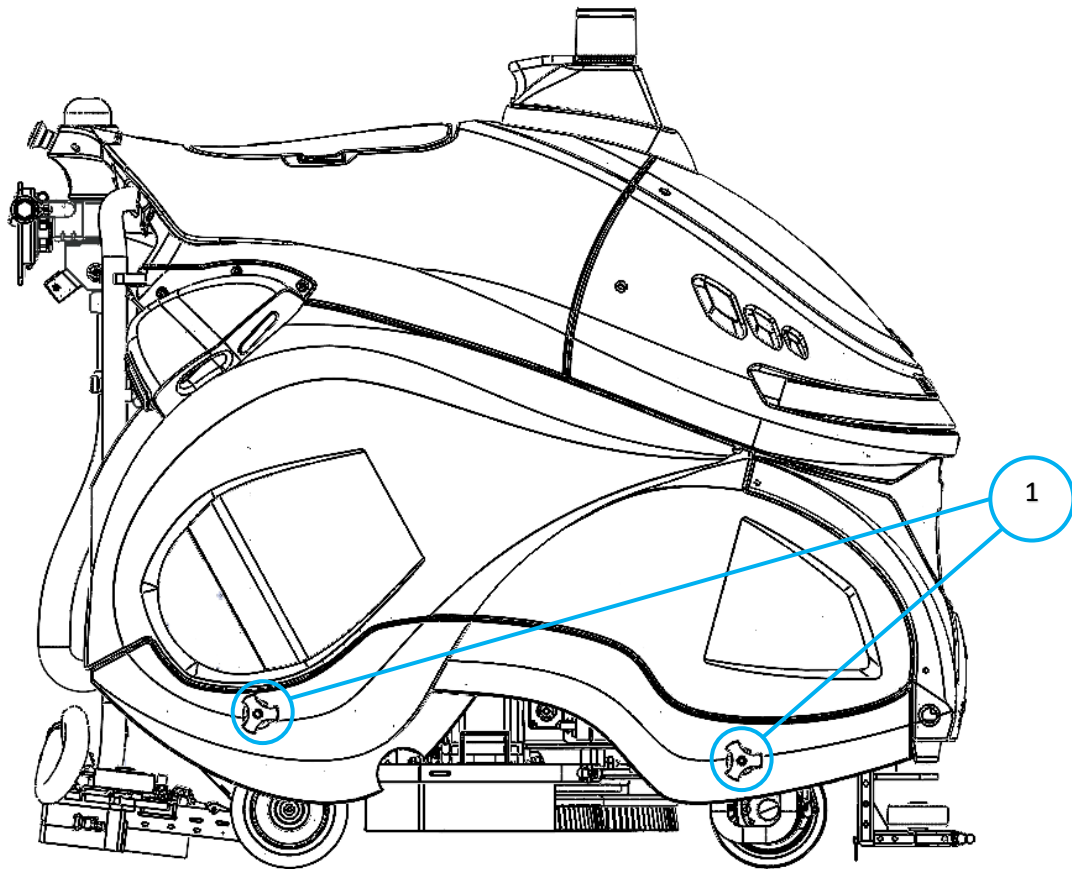

Fig. 1

1. Turn on the REX.
2. Check that clean water tank is empty, refer to [‘DRAINING THE CLEAN WATER TANK’](#).
3. Leave the draining tube pointed towards the drain. Ensure that the valve is in the open position.
4. Check clean water filter for debris/ choke and change if necessary, see section [DRAINING THE CLEAN WATER TANK’](#).
5. Connect the clean water hose to a water source, refer to [‘FILLING THE CLEAN WATER TANK’](#)
6. Turn on water supply and flush the clean water tank for a few minutes.
7. Turn off water supply and ball valve after flushing. Return draining tube and water tank hose onto REXSCRUB.
8. Fastens on side panels, by turning both knobs clockwise. Shown in Fig. 1 - 1.

REPLACING THE BRUSHES



Inspect the brush bristles for wear/ abrasion resulting in shortening. As a rule of thumb, replace the brushes when the cleaning bristles (white) have been worn down by half a centimeter, or monthly/ as needed.

1. Refer to the '[CLEANING THE BRUSHES](#)' section for detaching the brushes from their clutches.
2. To attach a new brush, follow the procedure described in '[MOUNTING THE BRUSHES](#)'.

REPLACING THE PADS



Inspect the pads for wear/ abrasion resulting in shortening or tearing. As a rule of thumb, replace the pads when they have been torn or worn down to expose the pad holder hooks.

1. A similar procedure to detaching the brushes from the '[CLEANING THE BRUSHES](#)' section applies to detaching the pad holders from the REXSCRUB clutches.
2. To replace a worn-out pad (Fig. 1 - 1), detach it from its pad holder (Fig. 1 - 2). Then unlatch the padlock (Fig. 1 - 3) to completely remove the pad from the pad holder.
3. Assemble a new pad onto the pad holder with the Padlock, and re-attach the pad holder to the robot clutch, following the same procedure for brushes as outlined in '[MOUNTING THE BRUSHES](#)'.

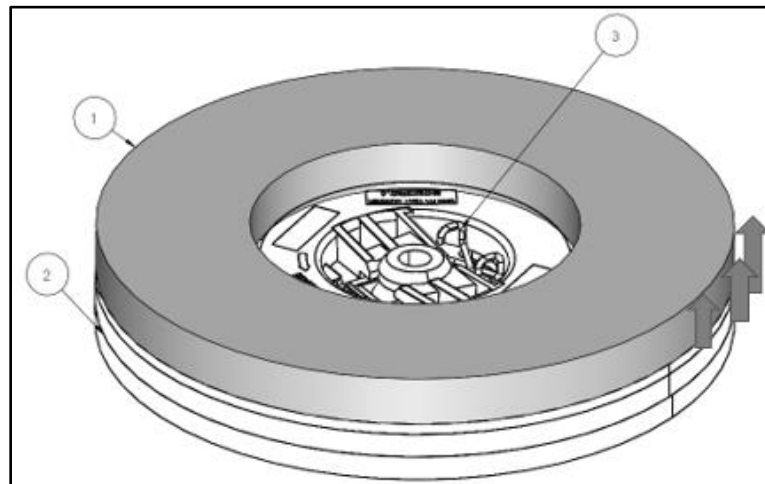

Fig. 1

BRUSHES AND PADS REPLACEMENT

MIXED-BRISTLE BRUSH: The REXSCRUB is equipped with a mixed-bristle brush (polyacetylene and grit bristles) generally suitable for scrubbing on a variety of floor types. The thick bristles are relatively rigid and therefore suitable for smoother floors in indoor use. Since the grit bristles are abrasive in nature, work only with the pressure adequate for cleaning; excessive scrubbing pressure applied to a single spot for an extended period could result in delamination.

PAD HOLDER: Pads are recommended to be used for cleaning shiny surfaces. A variety of scouring pads (typically available in peach and red colors) are suitable for use with the REXSCRUB for light daily cleaning of indoor floors.

Replacement brushes and pads can be purchased as consumables and order codes are listed below:

| CODE | QTY | NOTES |
|---------------------|-----|--|
| BRS-0016-C0 | 2 | MIXED-BRISTLES BRUSH (16") |
| BRS-0017-C0 | 2 | PAD HOLDER (16") |
| 0884-9-40095 | 2 | DIAMOND PAD (16") 3000 GRIT - GREEN |
| 0884-9-40096 | 2 | DIAMOND PAD (16") 400 GRIT - RED |
| 0884-9-40097 | 2 | GLOMESH (16") PEACH PAD |
| 0884-9-40098 | 2 | GLOMESH (16") BLACK PAD |
| 0884-9-40099 | 2 | GLOMESH (16") EMERALD HIGH PERFORMANCE STRIPPING PAD |

DETACHING THE SQUEEGEE HOSE



Detach the squeegee hose to inspect the squeegee hose/ squeegee trap for obstruction, and clear the choke as necessary:

1. Refer to the '[CLEANING THE SQUEEGEE](#)' section to remove the squeegee mount.

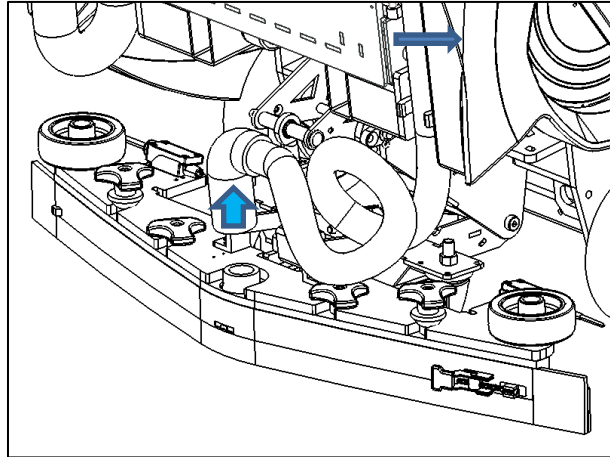

Fig. 1

2. Take off the hose (Fig.1), keeping a cloth handy in case of dirty water spillage.

REPLACING THE SQUEEGEE RUBBER



Inspect the squeegee rubber for wear resulting in shortened height/ tearing, and replace as necessary:

1. Remove the squeegee mount as described in '[CLEANING THE SQUEEGEE](#)'. Carefully store the wing bolts.
2. Detach the squeegee cartridge from the squeegee mount as described in '[INSTALLING NEW SQUEEGEE RUBBER ONTO SQUEEGEE MOUNT](#)'.
3. Peel off the front and rear rubber blades from the squeegee cartridge.
4. Refer to section '[INSTALLING NEW SQUEEGEE RUBBER ONTO SQUEEGEE MOUNT](#)' to attach the new front and rear blades and mount the squeegee cartridge back onto the squeegee mount.
5. Refer to section '[MOUNTING SQUEEGEE ASSEMBLY](#)' to mount the squeegee assembly back onto the REXSCRUB.

WIPING DOWN THE REXSCRUB



1. Ensure that the robot is powered off and the chemical cabinet is closed.
2. Only use a **DAMP CLOTH** to wipe down the outer skin of the robot.
3. Do not hose down the robot, or pour water directly onto the REX before wiping with cloth.

STORAGE IN COLD CLIMATES

Where robot is used in environments where frosting may occur, the robot clean water tank, recovery tank and hoses shall be emptied of fluid, to avoid cracking, bursting and clogging of hoses caused by freezing. The robot shall be stored in a dry and warm place.

PERIODIC MAINTENANCE

RECOMMENDED MAINTENANCE SCHEDULE

| OPERATION | AFTER EACH USE | DAILY | WEEKLY | MONTHLY | ANNUALLY |
|--|----------------|-------|--------|---------|----------|
| Draining recovery tank | | | | | |
| Cleaning squeegee | | | | | |
| Cleaning brushes | | | | | |
| Charge battery | | | | | |
| Wipe down sensors | | | | | |
| Wipe down robot | | | | | |
| Washing recovery tank | | | | | |
| Charging batteries | | | | | |
| Filling clean water tank | | | | | |
| Replacing chemical bottle | | | | | |
| Clean squeegee hose | | | | | |
| Replacing squeegee rubber | | | | | |
| Replace brushes | | | | | |
| Replace pads | | | | | |
| Check the brush floor skirt wear | | | | | |
| Check clean water filter | | | | | |
| Clean and check battery terminals and cables for damage. | | | | | |
| Chassis fastener Inspection | | | | | (1) |
| Check seals for wear | | | | | (1) |
| Check steering mechanism lubrication and tension | | | | | (1) |
| Motors and battery inspections | | | | | (1) |
| Tire inspection for wear | | | | | |

(1) = This maintenance procedure must be performed by an authorized service center or distributor.



CAUTION:

1. Switch off the robot and unplug batteries before performing any form of periodic maintenance.
2. For filling of the clean water tank, ensure that the water pressure is between 40 to 45 psi (tap water from normal commercial buildings is at 40 to 45 psi).
3. If any water leakage is seen from the water tank or tubing, contact the authorized distributor immediately.

REPLENISHING THE CHEMICAL



CAUTION: Refer to Appendix-A for Safe Handling of Chemical.

The chemical and defoamer bottle are accessible on the chemical cabinet. (Fig. 1 – 1). If the Chemical/ defoamer needs to be replenished, follow these steps to replace the bottle:

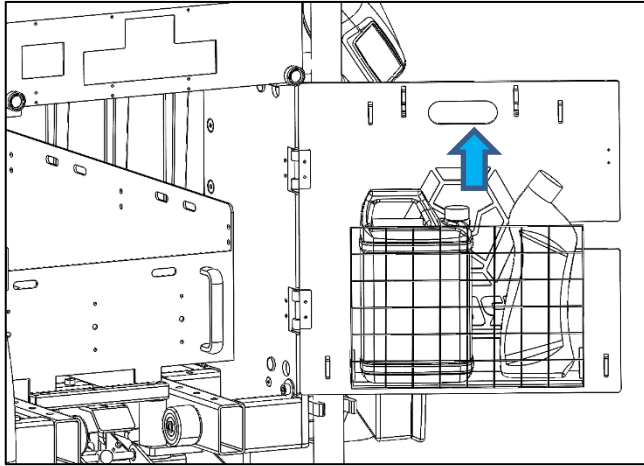

Fig. 1

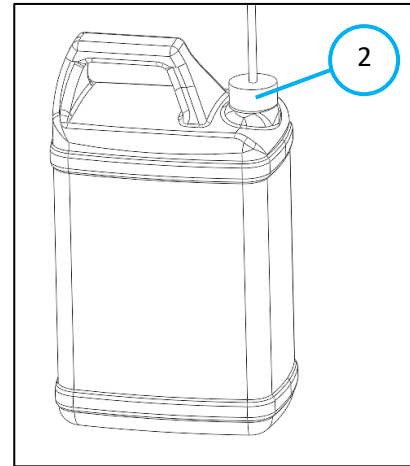

Fig. 2



1. Unmount the chemical/ defoamer bottle from the holding net (Fig. 1).
2. Detach the chemical bottle connecting hose by unscrewing cap (Fig. 2 - 2).
3. Remove the empty chemical bottle.
4. Prepare a new bottle, re-install it with the connecting hose and mount it on the hook-on net.
5. Repeat the same steps for the defoamer bottle.

CHANGING THE WATER FILTER

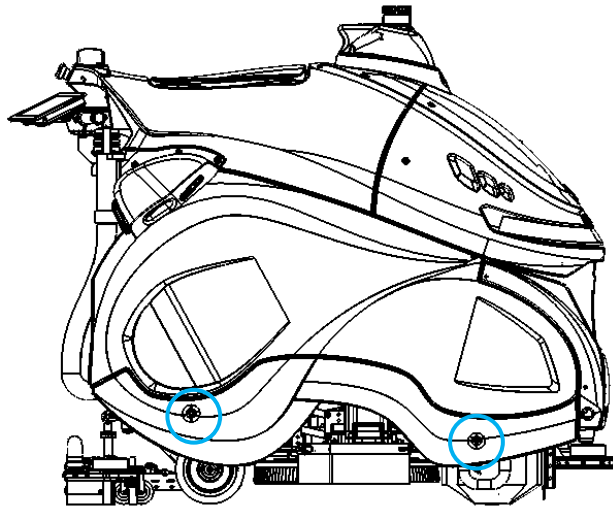

Fig. 1

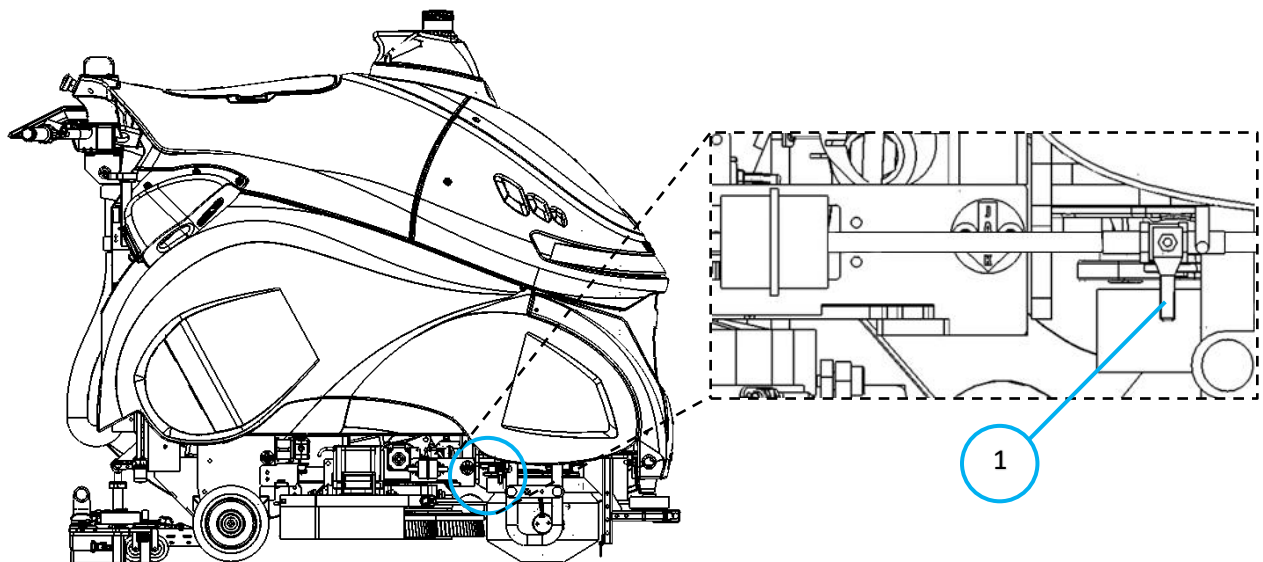

Fig. 2

1. Remove right side panel on the rex by turning two knobs shown in (Fig. 1) anti-clockwise.
2. Cut the cable ties.
3. Close the clean water tank valve.
4. Unplug hose from the water filter (Fig 2 – 1).
5. Throw away the old filter and replace with a new filter.



NOTE: Connect the water filter in the right direction of water flow – there is an arrow indicated on the filter. (Fig 3)

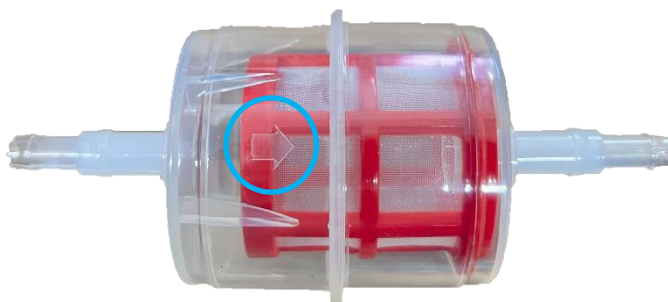

Fig. 3

6. Plug hose back to water filter, open the valve.
7. Secure with new cable ties.
8. Replace side panel and tighten the two blue knobs clock-wise.

CHARGING THE BATTERY

Refer to section [‘CHARGING THE BATTERY’](#) for instructions.

Refer to section [‘CHARGING THE BATTERIES’](#) for general safety instructions.

UPDATING THE MAPS

If there are permanent changes (for examples: obstacles, decorations) to the cleaning regions that may affect the robot’s operation using the facility maps, the maps need to be updated immediately. Contact an authorized distributor to confirm and test a new map for operation.

BATTERY INSTALLATION AND REPLACEMENT

For Installation and Replacement:

Contact authorized service provider or LionsBot for battery installation and replacement. See section [‘CONTACT INFORMATION’](#) or [‘DISTRIBUTER INFORMATION’](#) for contact details.



Warning: Do not tamper with or attempt to replace the battery yourself.

DISPOSAL

Contact an authorized distributor for the proper disposal of the REXSCRUB. Before scrapping the robot, it is necessary to separate out different categories of materials for proper collection and disposal in compliance with local environmental regulations. Take particular care in handling the batteries and electronic parts.

BATTERY DISPOSAL

It is important to dispose of the battery safely and in accordance with local environmental regulations. The battery must be removed from the robot before scrapping. Contact an authorized distributor for battery replacement. The battery characteristics are provided for reference below.

| Characteristics | Parameter |
|--------------------|--------------|
| Type | Lead Acid |
| Nominal Capacity | 310 Ah |
| Nominal Voltage | 36.0 V |
| Max charge voltage | 38.20 ± 0.2V |
| Cycle Life | >2000 |



NOTE: *dead batteries are classified as dangerous waste and as such must be delivered to an authorized body for disposal.*



DANGER: Following instructions can only be done by qualified personnel from distributor center.

1. Battery must be removed from the appliance before it is scrapped.
2. The appliance must be disconnected from the supply mains when removing the battery.



TROUBLESHOOTING

| PROBLEM | POSSIBLE CAUSE | SOLUTION |
|---|--|--|
| THE ROBOT DOES NOT START | The battery is out of charge | Perform a complete recharge cycle and attempt restarting the robot. |
| THE ROBOT DOES NOT MOVE | The E-Stop is triggered, indicated by red blinking lights | Release the E-stop and press the reset button. |
| | The safety Bumper is triggered, indicated by red blinking lights | Press the reset button. |
| THE ROBOT DOES NOT CLEAN WELL | Brush pressure is not suitable for the floor type | Consult an authorized distributor for help with adjusting brush pressure. |
| | The brushes/ pads are worn out | Replace with new brushes/ pads |
| THE SQUEEGEE LEAVES A TRACE OF WATER LEFT BEHIND | Vacuum has not started upon power on | Restart the robot and check if vacuum starts correctly |
| | Squeegee has not lowered upon power on | Restart the robot and check if squeegee lowers correctly |
| | The vacuum unit is obstructed | Make sure the squeegee trap is free of obstructions |
| | | Make sure the vacuum tube is free of obstructions |
| | Make sure the squeegee hose is clear; flush if necessary | |
| | The squeegee rubber blades are worn | Replace with new squeegee blades |
| THE ROBOT MOTION IS OFF THE LOCATION SET BY THE 'MOVE' COMMAND | There is an error in localization | Repeat the localization procedure, making sure the robot LIDAR scans match map features well |
| USER CANNOT LOGIN TO APP | Mismatched user id and password | Check the user id – password combination. Password is case sensitive. Contact an authorized distributor if necessary |
| CAN'T ADD ROBOT TO APP | Either the robot or app phone cannot connect to the internet | Check the network connection on both the robot and phone |
| CANNOT LOCALIZE ROBOT/ NAVIGATION ERRORS DURING OPERATION | Wrong map settings or robots' sensor not working | Check map and confirm the choice of the right map and place. Check LIDAR scans match map features well; clean LIDARs if necessary. |

The table above lists some useful troubleshooting tips for simple issues that may arise with the robot. If preliminary troubleshooting is unsuccessful, please contact an authorized distributor for assistance.

CONTACT INFORMATION

Original Equipment Manufacturer for REXSCRUB:

LionsBot International Pte Ltd

11 Changi South Street 3

#03-02 Singapore 486122

Email: hello@lionsbot.com

T: +65 6595 4565 | DID: +65 6595 4552

DISTRIBUTOR INFORMATION

APPENDIX A

Refer to below Safety Data Sheet when handling with Z Water

Hazards Identification

GHS Classification

Harmful to health ☒

- Acute toxicity (oral): Category 5
- Acute toxicity (inhalation, mist): Category 5

Harmful to the environment ☒

- Aquatic environment acute toxicity Not classified

Composition / Information on Ingredients

| Component Name | CAS | Composition |
|---------------------|-----------|-------------|
| Water | 7732-18-5 | >99% |
| Potassium hydroxide | 1310-58-3 | 0.17% |



First-Aid Measures

General Advice:

Take proper precautions to ensure your own health and safety before attempting rescue and providing first aid. Seek medical advice if you feel unwell. Show this safety data sheet to the doctor in attendance.

Inhalation:

If it is inhaled, move the person to a place with fresh air and keep him/her rest in a position comfortable for breathing.

Skin Contact:

If there is contact with skin, rinse with running water and wipe it dry. If there is symptom of inflammation, seek medical help.

Eye Contact:

If there is contact with eyes, immediately rinse eyes with running water for more than 15 minutes. Remove contact lenses and rinse the lenses. Seek medical help if necessary.

Ingestion:

If it is swallowed, drink large amount of water and seek medical help if necessary. Do not induce vomiting unless instructed by a physician.

Exposure Controls/Personal Protection



Hands protection:

Use rubber gloves.

Skin and physical protection:

Long sleeve, long pants, rubber boots.



Eye protection:

Wear safety glasses as a minimum eye protection. Conditions may warrant the use of chemical goggles and possibly a face shield. Consult your standard operating procedure or safety professional for advice.

Sanitary precaution:

In the case of allergy, wash hands and face after handling.